

## Features

- Bluetooth v4.2 specification compliant, supports both BR/EDR and BLE
- Bluetooth radio includes integrated balun
- Support A2DP 1.2, HFP 1.5 and AVRCP1.5
- 104MHz RISC MCU and 104MHz Voice Co-Processor(VoC) DSP core
- Internal MCU ROM and RAM, VoC memory and in-package serial flash memory.
- Various serial interfaces: USB OTG 2.0 HS, UART, I2C Master and SPI Master, SD Card Interface, IR receiver
- Support analog key
- Up to 4 PWM output
- Independent powered Real-Time Clock
- One channel 16 bits voice ADC and 16 bits stereo DAC
- Audio interfaces: PCM/I2S, analog stereo line in
- Support MP3/SBC/WMA/ACC decoder
- Support audio playback from SD/USB card
- Integrated broadcast FM tuner which can be tuned word-wide frequency band
- Debug host interface allowing non-intrusive in depth investigation GDB debugger
- Internal 32K OSC for standby, shutoff and sleep state
- Integrated BUCK and LDO

## General Description

RDA5856LE is a high performance, highly integrated multi-media system-on-chip solution with Bluetooth connectivity, which specialized in music and audio applications.

Integrating all essential electronic components, including baseband, bluetooth transceiver, power management, FM receiver onto a single system on chip, RDA5856LE offers best in class bill of material, space requirement and cost/feature ratio for bluetooth music and audio application.

## RDA5856LE

**High performance, highly integrated multi-media system-on-chip solution with bluetooth connectivity**

## Applications

- Bluetooth speakers
- Bluetooth music box
- Bluetooth headset or headphone

The 104MHz Voice Co-Processor supports various audio applications. The integrated audio codec supports two channels DAC and one channel ADC. Playback form SD card and USB card are also supported.

# Table of Contents

- Table of Contents ..... 2
- 1. Product Details ..... 3
- 2. Package and Pinout ..... 4
  - 2.1. Pin Assignment ..... 4
  - 2.2. Pin Description ..... 4
  - 2.3. Package Dimensions ..... 7
- 3. Function Block Diagram ..... 7
- 4. Clock and reset ..... 8
- 5. MCU ..... 8
- 6. USB ..... 8
- 7. VoC ..... 9
- 8. Flash Controller ..... 9
- 9. DMA ..... 9
- 10. AIF ..... 9
- 11. SDMMC Controller ..... 10
- 12. Timer ..... 10
- 13. GPIO ..... 10
- 14. UART ..... 10
- 15. Debug Host ..... 11
- 16. SPI Master ..... 11
- 17. I2C Master ..... 11
- 18. IR Receiver ..... 12
- 19. Calendar ..... 12
- 20. PWM ..... 12
- 21. Audio Codec ..... 13
- 22. Power Management ..... 13
  - 22.1. Power on/off control ..... 13
  - 22.2. Power Mode ..... 13
- 23. Bluetooth Transceiver ..... 14
- 24. FM ..... 14
- 25. Electrical Characteristics ..... 15
  - 25.1. BT RF Specifications ..... 15
  - 25.2. FM RF Specifications ..... 17
  - 25.3. Audio Characteristics ..... 18
  - 25.4. Recommended Operating Conditions ..... 18
- 26. Software ..... 18
- 27. Revision History ..... 19

## 1. Product Details

### Bluetooth Radio

- Fully compliant with Bluetooth radio specification 4.2 including basic rate, EDR and Bluetooth Low Energy.
- On-chip Balun which combines the balanced outputs of the PA on transmit and produces the balanced input signals for the LNA.

### Microcontrollers

- RDA in house developed 16/32 bit processor
- Reduced Instruction Set Architecture
- Efficient 6-stage instruction pipeline

### Voice Co-Processor

- RDA Internal designed Voice DSP core
- Two 16x16 -> 32 Multipliers
- Bi-MAC (two accumulations on the same register per cycle)
- Eight 16 bit general purpose registers and four 32 bit general purpose registers

### Audio Interface

- Audio codec with 16 bits stereo DAC and one channel 16 bits ADC
- Support sample rate of 8, 11.025, 12, 16, 22.05, 32, 44.1 and 48 KHz.

### Peripheral and Interfaces

- Debug host for debug and normal UART
- UART interface
- USB 2.0 OTG high speed interface, support USB audio
- SDMMC controller for SD card
- I2C master for internal and external modules access
- SPI master for internal and external modules access

- I2S interface which is compatible with PCM interface, support configurable MCLK output
- Up to 22 GPIOs
- IR receiver

### Integrated Power Management

- Buck DC-DC converter
- Multiple LDOs
- Low power mode supported

### Package Options

- LQFP48-EP

## 2. Package and Pinout

### 2.1. Pin Assignment

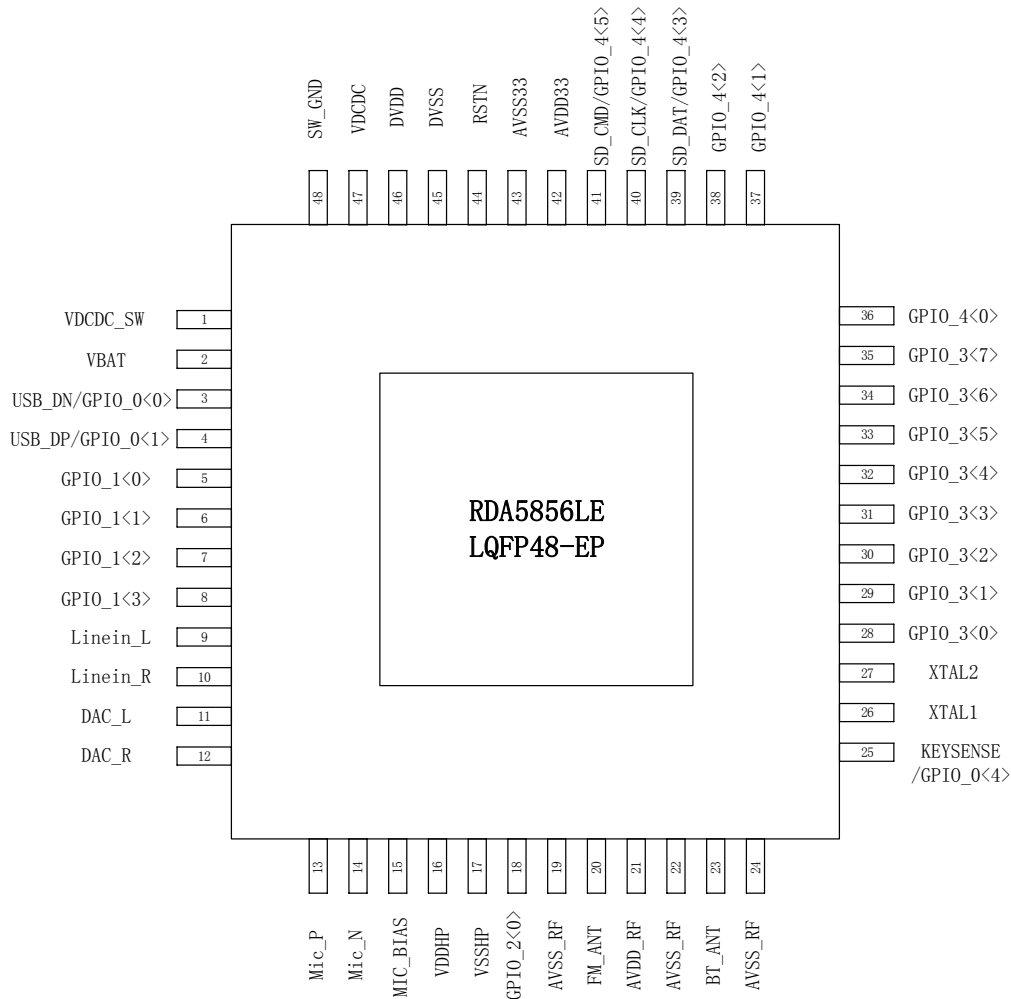

Figure 1 Pin Assignment

### 2.2. Pin Description

Table 1 Pin Types

Pin Type	Description
I/O	Digital input/output
I	Digital input
O	Digital output
A, I	Analog input
A, O	Analog output
A, I/O	Analog input/output
PWR	Power
GND	Ground

Table 2 Pin Description

PIN NO	NAME	TYPE	DESCRIPTION
1	VDCDC_SW	A, I	Switch-mode power regulator inductor connection
2	VBAT	PWR	Battery power supply
3	USB_DN/GPIO_00	A, I/O or I/O	Multiple functions configured by p00_cfg. 0: General purpose input/output 2: UART RXD 6: USB negative input 7: USB detect negative input

4	USB_DP/GPIO_01	A, I/O or I/O	Multiple functions configured by p01_cfg. 0: General purpose input/output 2: UART TXD 6: USB positive input 7: USB detect positive input
5	GPIO_10	I/O	Multiple functions configured by p10_cfg. 0: General purpose input/output 1: PMW output 0 2: SPI2 clock 3: I2C1 SDA 5: IR receiver input 7: GPIO interrupt input 0
6	GPIO_11	I/O	Multiple functions configured by p11_cfg. 0: General purpose input/output 1: PMW output 1 2: SPI2 chip select 0 3: I2C1 SCL 7: GPIO interrupt input 15
7	GPIO_12	I/O	Multiple functions configured by p12_cfg. 0: General purpose input/output 1: PMW output 2 2: SPI2 chip select 1 3: I2S DI
8	GPIO_13	I/O	Multiple functions configured by p13_cfg. 0: General purpose input/output 1: PMW output 3 2: SPI2 data output 3: I2S DO 7: GPIO interrupt input 14
9	LINEIN_L	A, I	Line input left
10	LINEIN_R	A, I	Line input right
11	DAC_L	A, O	DAC output left
12	DAC_R	A, O	DAC output right
13	MIC_P	A, I	Microphone input positive
14	MIC_N	A, I	Microphone input negative
15	MIC_BIAS	A, O	Microphone bias
16	AVDDHP	PWR	Power of analogue headphone
17	AVSSHP	GND	Ground of analogue headphone
18	GPIO_20	I/O	Multiple functions configured by p20_cfg. 0: General purpose input/output 4: Debug Host TXD 7: GPIO interrupt input 10
19	AVSS_RF	GND	Ground of analogue RF
20	FM_ANT	A, I	FM receiver input
21	AVDD_RF	PWR	Power of analogue RF
22	AVSS_RF	GND	Ground of analogue RF
23	BT_ANT	A, I/O	Bluetooth transmitter output/receiver input
24	AVSS_RF	GND	Ground of analogue RF
25	KEYSENSE/GPIO_04	A, I or I/O	Multiple functions configured by p04_cfg. 0: General purpose input/output 4: Debug Host RXD 5: Key input
26	XTAL1	A, I	XTAL input
27	XTAL2	A, O	XTAL output
28	GPIO_30	I/O	Multiple functions configured by p30_cfg. 0: General purpose input/output 2: UART RXD 3: I2C1 SDA
29	GPIO_31	I/O	Multiple functions configured by p31_cfg. 0: General purpose input/output 2: PWM output 3 3: UART TXD 4: I2C1 SCL
30	GPIO_32	I/O	Multiple functions configured by p32_cfg. 0: General purpose input/output 2: PWM output 2 3: UART CTS 4: I2S DI
31	GPIO_33	I/O	Multiple functions configured by p33_cfg. 0: General purpose input/output 2: PWM output 1 3: UART RTS 4: I2S DO
32	GPIO_34	I/O	Multiple functions configured by p34_cfg. 0: General purpose input/output

			2: PWM output 0 4: I2S LRCK 7: GPIO interrupt input 9
33	GPIO_35	I/O	Multiple functions configured by p35_cfg. 0: General purpose input/output 4: I2S BCK
34	GPIO_36	I/O	Multiple functions configured by p36_cfg. 0: General purpose input/output 2: UART RXD 3: I2S MCLK output 7: GPIO interrupt input 8
35	GPIO_37	I/O	Multiple functions configured by p37_cfg. 0: General purpose input/output 1: PWM output0 2: UART TXD 3: I2S BCK 4: Debug Host TXD 7: GPIO interrupt input 6
36	GPIO_40	I/O	Multiple functions configured by p40_cfg. 0: General purpose input/output 1: PWM output 1 4: Debug Host RXD 5: SD D3 7: GPIO interrupt input 5
37	GPIO_41	I/O	Multiple functions configured by p41_cfg. 0: General purpose input/output 1: PWM output 2 3: I2S MCLK output 4: Debug Host TXD 5: SD D2 7: GPIO interrupt input 4
38	GPIO_42	I/O	Multiple functions configured by p42_cfg. 0: General purpose input/output 1: PWM output 3 3: I2S BCK 4: Debug Host RXD 5: SD D1 7: GPIO interrupt input 3
39	SD_DAT/GPIO_43	I/O	Multiple functions configured by p43_cfg. 0: Debug Host Clock 3: General purpose input/output 5: SD data 7: GPIO interrupt input 2
40	SD_CLK/GPIO_44	I/O	Multiple functions configured by p44_cfg. 0: Debug Host RXD 3: General purpose input/output 5: SD clock 7: GPIO interrupt input 1
41	SD_CMD/GPIO_45	I/O	Multiple functions configured by p45_cfg. 0: Debug Host TXD 3: General purpose input/output 5: SD command 7: GPIO interrupt input 0
42	AVDD33	PWR	Power of analogue of 3.3V
43	AVSS33	GND	Ground of analogue 3.3V
44	RSTN	I	External reset input, active low
45	DVSS	GND	Ground of digital core
46	DVDD	PWR	Power of digital core
47	VDCDC	PWR	Power of switch mode regulator
48	SW_GND	GND	Ground of switch mode regulator

### 2.3. Package Dimensions

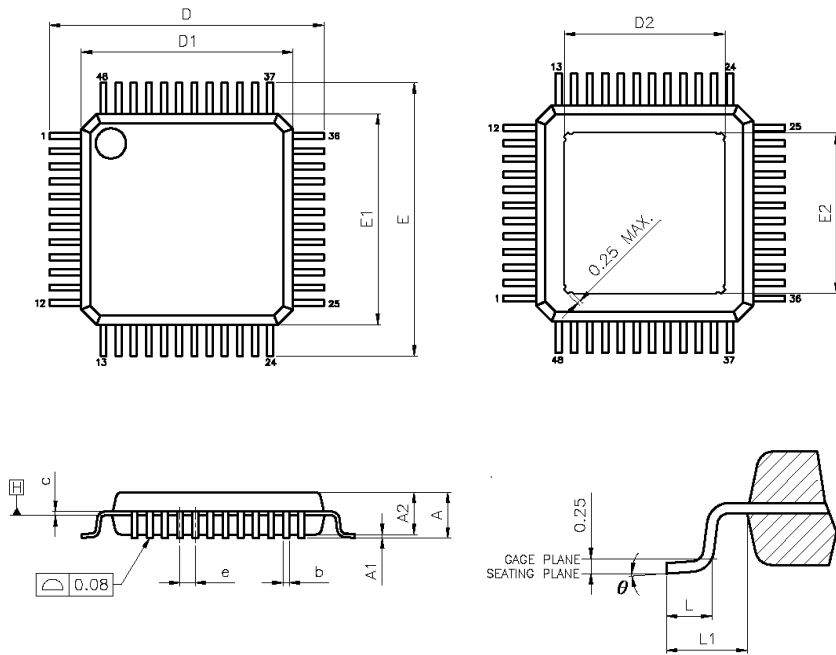

VARIATIONS (ALL DIMENSIONS SHOWN IN MM)

SYMBOLS	MIN.	NOM.	MAX.
A	---	---	1.60
A1	0.05	---	0.15
A2	1.35	1.40	1.45
b	0.17	0.22	0.27
c	0.09	---	0.20
D	9.00 BSC		
D1	7.00 BSC		
E	9.00 BSC		
E1	7.00 BSC		
e	0.50 BSC		
L	0.45	0.60	0.75
L1	1.00 REF		
$\theta$	0°	3.5°	7°

THERMALLY ENHANCED DIMENSIONS(SHOWN IN MM)

PAD SIZE	E2		D2	
	MIN.	MAX.	MIN.	MAX.
20*X20*	4.31	5.36	4.31	5.36

- NOTES:
1. JEDEC OUTLINE :  
MS-026 BBC  
MS-026 BBC-HO(THERMALLY ENHANCED VARIATIONS ONLY)
  2. DATUM PLANE [H] IS LOCATED AT THE BOTTOM OF THE MOLD PARTING LINE COINCIDENT WITH WHERE THE LEAD EXITS THE BODY.
  3. DIMENSIONS D1 AND E1 DO NOT INCLUDE MOLD PROTRUSION. ALLOWABLE PROTRUSION IS 0.25 mm PER SIDE. DIMENSIONS D1 AND E1 DO INCLUDE MOLD MISMATCH AND ARE DETERMINED AT DATUM PLANE [H].
  4. DIMENSION b DOES NOT INCLUDE DAMBAR PROTRUSION.

### 3. Function Block Diagram

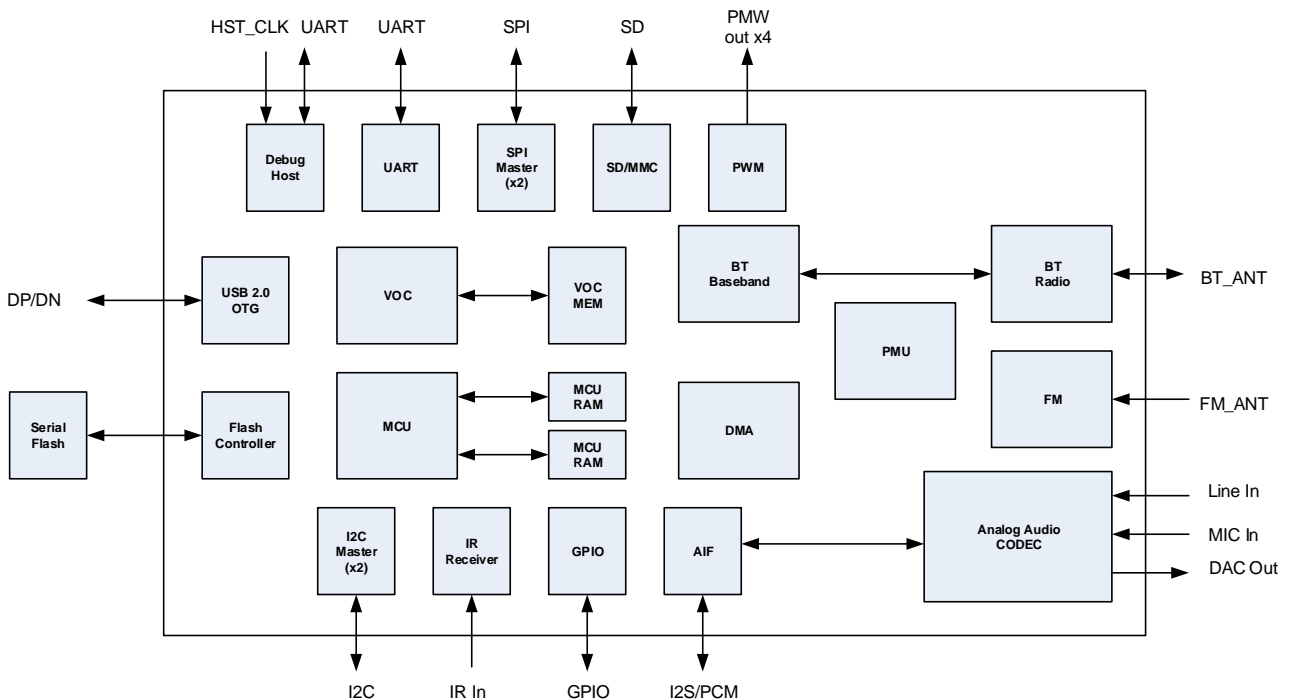

Figure 2 RDA5856LE Block Diagram

## 4. Clock and reset

RDA5856LE has a reference clock input from either a crystal or an external clock source. There are two internal PLL which use XTAL clock as reference. They are used for system and audio applications.

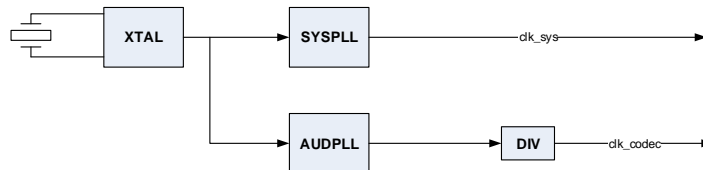

Figure 3 Clock Structure

RDA5856LE has several reset sources, as following:

- POR
  - Entire SoC is reset after power supply ramping from 0v to VBAT.
- External Pin Reset
  - Entire SoC is reset except PMU.
- Warm Reset
  - ✓ Global soft reset
    - DBB can be reset by set soft reset register in system control register map.
  - ✓ Watch Dog Reset
    - DBB will be reset when watch dog timer expired.

## 5. MCU

RDA RISC is a 16/32-bits processor which using a Reduced Instruction Set Architecture, an efficient 6-stage instruction pipeline, it provides high performance to the system.

- RDA RISC Core.
  - ✓ 32x32-bit Multiplier.
  - ✓ 32x32-bit -> 64-bit Multiplier Accumulator (MAC) in 2 cycles (pipelined).
  - ✓ Read / Write Buffer.
  - ✓ 16/32 bit instruction set.
- 32 interrupt sources.
- TCM interface for ROM and flash code read

## 6. USB

RDA5856LE has a high-speed USB OTG interface for communicating with other devices, such as PC or USB card. Bothe USB PHY and Link layer is integrated. It supports both host and device. USB role detection is included to support USB Type A.

- Operates either as the host/peripheral in point-to-point communications with another USB function or as a function controller for a USB peripheral
- Complies with the USB 2.0 standard for high-speed (480 Mbps) functions
- Supports point-to-point communications with one high-, full- or low-speed device
- Integrated USB PHY with ESD protection circuits
- Supports Control, Interrupt, Bulk and Isochronous transfer
- 5 Endpoint with FIFOs
  - ✓ One Bi-directional Control Endpoint (EPO)
  - ✓ Four soft configurable Bi-directional Endpoints
- Certified compliant with the On-The-Go supplement
- Supports Session Request Protocol (SRP) and Host Negotiation Protocol (HNP)



## 7. VoC

The VoC is designed to process different vocoders. It is developed as a target-specific DSP core, including basic function-call support. It executes the code with very little control intervention from the MCU. It is controlled and configured by the CPU through the AMBA bus.

- Bi-MAC, single test/logic Computational Unit with two 16x16 -> 32-bit multipliers
- Eight 16-bit general purpose registers that can be combined in four 32-bit general purpose registers.
- All 16-bit registers can be used as pointers; four of them are incremental (for easy array addressing).
- Four 32-bit general purpose registers.
- Double stack with random access: for 32-bit & 16-bit values (push, pop).
- Functions call support (jal, return).
- Two zero-cycle loop counters.
- Pointer & Direct addressing modes.
- DMA sub-module for block transfers between external memory and VoC memories.

## 8. Flash Controller

The Flash controller provides instruction/data management on serial Flash devices. A command poll is used to support variable commands for variable flash devices. Up to one 512/256Mb Flash or two 128Mb (16MB) Flash devices are supported using Standard, or Dual or Quad SPI. Besides the normal Flash read mode using register address through RX FIFO, the Flash controller provides an XIP mode, in which CPU can read Flash address range as RAMs.

- Flash size up to 512Mb x 1, or 256Mb x 1, or 128Mb x 2
- Standard, Dual, Quad SPI.
- Up to 52MHz SPI clock.
- Command poll to support variable Flash commands, including advanced read commands.
- Normal Read & XIP mode.

## 9. DMA

RDA5856LE support various DMA functions. It supports memory to memory, memory to peripheral, peripheral to memory transfers. For transfers between memory and peripheral, hardware handshake is supported and multiple DMA channels shared with peripherals.

- Support for linear memory transfers.
- Multiple DMA channels
- Support for word, half-word and byte aligned addresses.
- Burst transfer supported
- Interrupt generation at completion of the transaction.
- Can fill a part of the memory with a 32-bit pattern.
- Frame Check Sequence computation

## 10. AIF

The Audio Interface (AIF) module is the audio interface between the system and internal/external audio codec.

- Common features
  - ✓ All common DTMF and Comfort Tones can be generated and gained from -15 dB to 0 dB

- ✓ Side Tone fully configurable: Mute or amplification from -36 dB to +6 dB
- ✓ Loop back capabilities for test purposes.
- Serial Interfaces.
  - ✓ 16-bit mono or stereo samples.
  - ✓ MSB/LSB configurable.
  - ✓ Configurable as master or slave.
  - ✓ LRCK/BCLK ratio from 16 to 31.
  - ✓ Supports multiple sample rates (8 kHz; 11.025 kHz; 12 kHz; 16 kHz; 22.05 kHz; 24 kHz; 32 kHz; 44.1 kHz; 48 kHz).
  - ✓ Fully configurable clock polarity.
  - ✓ Configurable TX/RX data delays.
  - ✓ Support Audio Mode: I2S compatible
  - ✓ Support Voice Mode: One cycle strobe pulse at the beginning of each new sample.
- Parallel Interface
  - ✓ 16-bit mono samples from ADC.
  - ✓ 16-bit stereo samples to stereo DAC.
  - ✓ Separate TX and RX strobe lines for synchronization.

## 11. SDMMC Controller

This module connects inner bus and outer SD or MMC card. It receives the inner command and data, transfers it to outer SD or MMC card, and transfer response or data back.

- SD Card Specification Version 2.0
- SDIO Version 1.10
- MMC specification Version 3.1
- Hot insertion and removal of media cards will be considered by GPIO module

## 12. Timer

There are three different timers.

- 1 24-bit decremental timer for OS, ticks of 16384Hz.
- 1 32-bit incremental hardware delay timer, ticks of 16384Hz.
- 1 24-bit decremental watchdog timer, ticks of 32768Hz.
- Multiple IRQ sources: timers wrap, interval arrives.

## 13. GPIO

GPIO module has configurable number of General Purpose Input or Output ports (GPIO).

- Up to 22 GPIOs configurable as input or output.
- Up to 11 GPIOs can generate interrupt.
- Various interrupt triggered mode.
  - ✓ Rising/Falling edge.
  - ✓ High/Low level.

## 14. UART

RDA5856LE includes UART which can be used as a serial interface or as an IrDA interface.

- Smooth stop feature (the UART stops after the end of the current word transfer).
- Break generation and detection.
- Supports Automatic Flow Control (CTS and RTS lines).

- Supports low speed IrDA 1.0 SIR mode by adding external hardware.
- DMA capabilities to allow fully automated data transfers.
- Wide selection of programmable interrupts to allow interrupt driven data transfer management.
- Loop Back capabilities for test purposes.

## 15. Debug Host

Debug Host module contains 1 normal Universal Asynchronous Receiver Transmitter channels (UART) and 1 Debug UART. The two UARTs share the same TX/RX engines, which sends and receives byte data from serial interface. Each UART has its own control sub-module and own APB interface. Debug Host module parses the incoming data from serial interface to switch between the normal UART and the Debug UART.

### ■ Normal UART

The normal UART can be used for traces and other purposes. For APB interface, it is exactly the same to the other UARTs in the system. However, if Debug UART is enabled, it should have the same serial interface configuration as the Debug UART. Some of its configuration options will be masked in this case. To adapt different clock frequency, the normal UART uses asynchronous FIFO, which uses gray code to represent the read and write pointer positions.

### ■ Debug UART

The Debug UART is specially designed for communicating debug information with a PC host. The serial interface of Debug UART is a simplified version of the normal UART and is less configurable. Each sample is sent serially, has 1 start bit (always zero), 8 data bits, and 1 stop bits (always one). Breaks (data line held low) can be generated and detected allowing resynchronizing the two devices.

## 16. SPI Master

This module is a master interface for a synchronous serial link, it can be configured to be compatible with Motorola SPI or to comply with some various synchronous serial protocols.

- Multiple chip selects and selectable data input.
- Programmable clock polarity.
- Programmable data frame size (from 4 to 32 bits).
- A few delay options (time between CS, clocks and data).
- Received pattern matching before filling RX FIFO (SD-MMC read block feature)
- Transmit zero when TX FIFO empty (for generating dummy data during pattern matching read)
- Direct pin control to force value to 0, 1 or input.
- Special read mode with output enable control of the DO pin (selected input should be multiplexed with DO pin to use this feature).

## 17. I2C Master

RDA5856LE has I2C master which supports 100Kbps and 400Kbps.

- Compatible with Philips I2C standard
- Multi Master Operation
- Software programmable clock frequency
- Clock stretching and wait state generation
- Software programmable acknowledge bit

- Interrupt or bit-polling driven byte-by-byte data-transfers
- Arbitration lost interrupt, with automatic transfer cancellation
- Start/Stop/Repeated Start/Acknowledge generation
- Start/Stop/Repeated Start detection
- Bus busy detection
- Supports 7 and 10bit addressing mode
- Operates from a wide range of input clock frequencies

## 18. IR Receiver

The IR receiver module performs serial-to-parallel conversion on received data from a peripheral device. It supports NEC, RC-5 and Philips 9012 mode.

- Support 3 IR modes, NEC, RC-5 and Philips 9012
- Store data code and user code
- Support data code and user code verify
- Enable Interrupt when data received
- Support system wakeup, even without APB bus clock
- Configurable frame time, bit time, high-time and low-time

## 19. Calendar

The calendar module provides date and time information. It works on the 32.768 KHz oscillator with independent power supply. In addition to provide timing data, alarm interrupt is generated and it is also used to power-up the baseband core by sending wakeup signal.

- Independent power supply.
- Counters for second, minute, hour, day, month, year and day of week.
- Maxim day of each month stored in module, leap year supported.
- Alarm generate, wakeup triggered by alarm. Alarm IRQ.
- Periodical IRQ for certain intervals.

## 20. PWM

The PWM module generates 4 independent PWM outputs, utilizing 3 specialized modulation schemes. All PWM outputs can be configured to PWL, PWT and LGP mode.

- Pulse Width Tone (PWT)
  - ✓ Generates square wave output capable of driving piezo electric speaker
  - ✓ Variable frequency between 349Hz and 5276Hz with 12 half-tone frequencies per octave
  - ✓ Volume control
- Light Pulse Generation (LPG)
  - ✓ Adjustable PWM frequency is from 0.01Hz ~ 6.5MHz
  - ✓ Adjustable on-time/off-time is from 0.77us to 50s.
  - ✓ Customized output mode for square wave
- Pulse Width Light (PWL)
  - ✓ Pseudo random bit sequence with output on-time proportional to a programmed threshold value
  - ✓ Minimizes flicker

## 21. Audio Codec

The audio codec has one channel voice ADC and audio DAC, which supports mono voice input and stereo audio output. It also has flexible mixing and loopback paths to support variable scenario requirements, such as side tone, FM recording, etc.

- One channel 16 bits ADC and 16 bits stereo DAC
- Mono input for voice and audio band, input resistance is typically 4KΩ.
- Integrated mic bias which don't need external load capacitor with configurable output voltage
- Stereo outputs are supported, could drive 16Ω/32Ω headphone, or act as line-out.
- Support sample rate of 8, 11.025, 12, 16, 22.05, 32, 44.1 and 48 KHz.
- Configurable gain for audio input and output path, gains control is implemented in both digital and analog.
- Stereo FM playback.
- Flexible audio/voice path mixing/loopback.

## 22. Power Management

PMU integrated buck DC-DC converter and multiple LDOs.

### 22.1. Power on/off control

PMU performs a POR once battery is connected which resets all components in chip. PMU can be configured to support either hard mode power on or soft mode power on.

- Hard mode

No power key implementation is needed. System is powered on once battery is connected.

- Soft mode

An extra key press (i.e. Power on key pressed) is needed to power on the system.

### 22.2. Power Mode

The PMU implements multiple power mode defining the LDOs and DC/DC activation in various modes.

- Power Off Mode  
Used when the system is off (system has been shut-off or first time battery is plugged...). In this case only V<sub>RTC</sub> is provided.
- Power On Mode  
After Power Up sequence, all LDOs that have “reset state ON” are activated.
- Active Power Mode  
Used once system has booted and decides to switch from “Power On Mode”. This mode is programmable.
- Low Power Mode  
Used when the system goes to low-power mode. This mode is programmable.

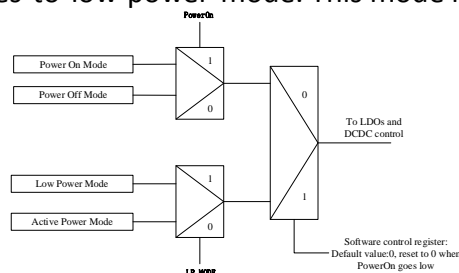

Figure 4 Principle schematic for Power-profile usage

## 23. Bluetooth Transceiver

RDA5856LE integrated bluetooth baseband and radio which has been designed to provide low power, low cost and robust communications for Bluetooth application. It is fully compliant with Bluetooth radio specification 4.2 including basic rate, EDR to 3MHz and Bluetooth Low Energy. RDA5856LE contains an on-chip Balun which combines the balanced outputs of the PA on transmit and produces the balanced input signals for the LNA.

- Baseband
  - The BT baseband core handles packet and bit stream processing including packing/unpacking for different packet types, error checking, whitening/de-whitening, error correction, and encryption/decryption and so on.
  - ✓ Compliant with Bluetooth 4.2 + EDR specification
    - Support BR, EDR 2M/3M, BLE
    - Support SCO/eSCO
    - BLE whitelist
    - BLE data packet length extension
    - BLE ping
  - ✓ Bluetooth Piconet and Scatternet support
  - ✓ Low power support and optimization
    - Support AFH
    - Sniff Subrating
    - Enhance Inquiry Response
    - Sleep on 32.768KHz clock
  - ✓ Test Mode support
    - BR/EDR Transmitter test and Loopback test
    - BLE direct test mode
    - Fixed pattern, PRBS-9, PRBS-15 or user defined pattern
- RF Receiver
  - The receiver features a low-IF architecture that enables the channel select filters to be integrated onto the die. The down converted signal is digitalized by a sigma-delta AD and further processed by a digital demodulator. The receiver path provides a low noise figure, a high degree of linearity and an extended dynamic range.
- RF Transmitter
  - The transmitter features a direct IQ modulator to minimize frequency drift during a packet, which results in a well-controlled modulation index. The digital modulator performs the data modulation and filtering required for the Bluetooth signal. The internal PA has a programmable output power that meets Class 2 and class3 Bluetooth radio requirements without an external RF PA.
- RF Synthesizer
  - The radio synthesizer is fully integrated onto the die with no requirement for external LC resonators or loop filter. The synthesizer provides fast frequency locking and low phase noise to meet Bluetooth specification.

## 24. FM

RDA5856LE integrates a broadcast FM stereo radio tuner with fully integrated synthesizer and MPX decoder. The tuner requires the least external component. It has a powerful low-IF digital audio

processor, this make it has optimum sound quality with varying reception conditions. It can be tuned to the worldwide frequency band.

- Low Power Consumption
- Support worldwide frequency band
  - ✓ 65-108MHz
- Digital low-IF tuner
  - ✓ Image-reject down-converter
  - ✓ High performance A/D converter
- Fully integrated digital frequency synthesizer
  - ✓ Fully integrated on-chip RF and IF VCO
  - ✓ Fully integrated on-chip loop filter
- Autonomous search tuning
- Auto gain control (AGC)
- Digital adaptive noise cancellation
  - ✓ Mono/stereo switch
  - ✓ Soft mute
  - ✓ Soft blending
- Programmable de-emphasis (50/75 us)
- Receive signal strength indicator (RSSI)
- Bass boost
- Volume control
- 32.768 KHz Reference Clock
- I2C control bus interface
- Directly support 32Ω resistance loading

## 25. Electrical Characteristics

### 25.1. BT RF Specifications

Receiver Characteristics --- Basic Data Rate (VBAT = 4.0 V, TA = +27°C, unless otherwise specified)

SYMBOL	PARAMETER	CONDITION	MIN	TYP.	MAX	UNIT
General Specification						
	Sensitivity @ 0.1% BER		/	-93	/	dBm
	Maximum input @ 0.1% BER		0	/	/	dBm
	C/I co-channel		/	/	9	dB
Adjacent channel selectivity C/I		F = F0 + 1 MHz	/	/	-12	dB
		F = F0 - 1 MHz	/	/	-10	dB
		F = F0 + 2 MHz	/	/	-40	dB
		F = F0 - 2 MHz	/	/	-40	dB
		F = F0 + 3 MHz	/	/	-45	dB
		F = F0 - 3 MHz	/	/	-45	dB
		F = F_image	/	/	-10	dB
Out-of-band blocking		30MHz–2000MHz	-10	/	/	dBm
		2000MHz–2400MHz	-20	/	/	dBm
		2500MHz–3000MHz	-20	/	/	dBm
		3000MHz–12.5GHz	-10	/	/	dBm

Inter-modulation		-34	/	/		dBm
------------------	--	-----	---	---	--	-----

**Transmitter Characteristics --- Basic Data Rate (VBAT = 4.0 V, TA = +27°C, unless otherwise specified)**

SYMBOL	PARAMETER	CONDITION	MIN	TYP.	MAX	UNIT
<b>General Specification</b>						
	Max RF output power		/	8	/	dBm
	Power control step		/	3	/	dB
	20dB bandwidth		/	0.92	/	MHz
	Adjacent channel transmitter power	$ M - N  = 2 \text{ MHz}$	/	/	-52	dBm
		$ M - N  \geq 3 \text{ MHz}$	/	/	-55	dBm
	$\Delta f_{1\text{avg}}$ Maximum modulation		/	152	/	kHz
	$\Delta f_{2\text{avg}}/\Delta f_{1\text{avg}}$		/	0.97	/	/
	ICFT		/	/	10	kHz
	Drift (1 slot packet)		/	10	/	kHz
	Drift (5 slot packet)		/	10	/	kHz

**Receiver Characteristics --- Enhanced Data Rate (VBAT = 4.0 V, TA = +27°C, unless otherwise specified)**

SYMBOL	PARAMETER	CONDITION	MIN	TYP.	MAX	UNIT
<b><math>\pi/4</math> DQPSK</b>						
	Sensitivity @0.01% BER		/	-92.5	/	dBm
	Maximum input @ 0.1% BER		-3	/	/	dBm
	C/I co-channel		/	/	10	dB
Adjacent channel selectivity C/I		$F = F_0 + 1 \text{ MHz}$	/	/	-10	dB
		$F = F_0 - 1 \text{ MHz}$	/	/	-8	dB
		$F = F_0 + 2 \text{ MHz}$	/	/	-39	dB
		$F = F_0 - 2 \text{ MHz}$	/	/	-39	dB
		$F = F_0 + 3 \text{ MHz}$	/	/	-45	dB
		$F = F_0 - 3 \text{ MHz}$	/	/	-45	dB
		$F = F_{\text{image}}$	/	/	-8	dB
<b>8DPSK</b>						
	Sensitivity @0.01% BER		/	-82.5	/	dBm
	Maximum input @ 0.1% BER		-5	/	/	dBm
	C/I co-channel		/	/	20	dB
Adjacent channel selectivity C/I		$F = F_0 + 1 \text{ MHz}$	/	/	-2	dB
		$F = F_0 - 1 \text{ MHz}$	/	/	0	dB
		$F = F_0 + 2 \text{ MHz}$	/	/	-28	dB
		$F = F_0 - 2 \text{ MHz}$	/	/	-28	dB
		$F = F_0 + 3 \text{ MHz}$	/	/	-38	dB
		$F = F_0 - 3 \text{ MHz}$	/	/	-38	dB
		$F = F_{\text{image}}$	/	/	0	dB

**Transmitter Characteristics --- Enhanced Data Rate (VBAT = 4.0 V, TA = +27°C, unless otherwise specified)**

SYMBOL	PARAMETER	CONDITION	MIN	TYP.	MAX	UNIT
<b>General Specification</b>						
	Max RF output power		/	4	/	dBm



Relative transmit power		/	-1.5	/	dB
$\pi/4$ DQPSK max $w_0$		/	-5	/	kHz
$\pi/4$ DQPSK max $w_i$		/	20	/	kHz
$\pi/4$ DQPSK max $ w_i + w_0 $		/	17	/	kHz
8DPSK max $w_0$		/	-2	/	kHz
8DPSK max $w_i$		/	17	/	kHz
8DPSK max $ w_i + w_0 $		/	17	/	kHz
$\pi/4$ DQPSK Modulation Accuracy	RMS DEVM	/	10	/	%
	DEVM < 30%	/	100	/	%
	Peak DEVM	/	/	24	%
8DPSK Modulation Accuracy	RMS DEVM	/	10	/	%
	DEVM < 30%	/	99.8	/	%
	Peak DEVM	/	/	22	%
$\pi/4$ DQPSK In-band spurious emissions	$ M - N  = 1$ MHz	/	/	-38	dBc
	$ M - N  = 2$ MHz	/	/	-36	dBm
	$ M - N  \geq 3$ MHz	/	/	-41	dBm
8DPSK In-band spurious emissions	$ M - N  = 1$ MHz	/	/	-37	dBc
	$ M - N  = 2$ MHz	/	/	-36	dBm
	$ M - N  \geq 3$ MHz	/	/	-40	dBm
EDR Differential Phase Coding		/	100	/	%

## 25.2. FM RF Specifications

(VDD = 2,7 to 5,5V, TA = -25°C to 85 °C, unless otherwise specified)

SYMBOL	PARAMETER	CONDITIONS	MIN	TYP	MAX	UNIT
<b>General Parameters</b>						
$F_{in}$	FM Input Frequency	BAND=00	87		108	MHz
		BAND=01	76		91	MHz
		BAND=02	76		106	MHz
		BAND=03	65		76	MHz
$V_{rf}$	Sensitivity <sup>1,2,3</sup>	(S+N)/N=26dB		2		$\mu$ V EMF
$R_{in}$	LNA Input Resistance <sup>7</sup>			150		$\Omega$
$C_{in}$	LNA Input Capacitance <sup>7</sup>		2	4	6	pF
(S+N)/N	Maximum Signal Plus Noise to Noise Ratio <sup>1,2</sup>		55	60	-	dB
THD	Audio Total Harmonic Distortion <sup>1,3,6</sup>			0.15	0.2	%
$R_L$	Audio Output Loading Resistance	Single-ended		32		$\Omega$
<b>Pins L<sub>NAN</sub>, L<sub>NAP</sub></b>						
$V_{com\_rfin}$	Pins L <sub>NAN</sub> and L <sub>NAP</sub> Input Common Mode Voltage			0		V
$V_{com}$	Audio Output Common Mode Voltage		0.95	1	1.05	V

Notes:

1.  $F_{in}$ =65 to 115MHz;  $F_{mod}$ =1KHz; de-emphasis=75  $\mu$ s; MONO=1; L=R unless noted otherwise;
2.  $f$ =22.5KHz; 3.  $B_{AF}$  = 300Hz to 15KHz, RBW  $\leq$ 10Hz; 4.  $|f_2-f_1| > 1$ MHz,  $f_0=2 \times f_1-f_2$ , AGC disable,  $F_{in}$ =76 to 108MHz;
5.  $P_{RF}$ =60dBuV; 6.  $f$ =75KHz,  $f_{pilot}$ =10%
7. Measured at  $V_{EMF} = 1$  mV,  $f_{RF} = 65$  to 108MHz
8. At LOUT and ROUT pins
9. Adjustable

### 25.3. Audio Characteristics

To be added

### 25.4. Recommended Operating Conditions

Operating Condition		Min	Typ	Max	Unit
Operating Temperature Range		-20	20	65	$^{\circ}$ C
VBAT		3.4	3.8	4.35	V
AVDDHP		2.22	2.48	2.76	V
AVDD33		2.88	3.25	3.3	V
DVDD		1.02	1.2	1.44	V
VDCDC/ AVDD_RF	DC-DC Mode	1.36	2.14	2.8	V
VDCDC/ AVDD_RF	LDO Mode	2.23	2.37	2.53	V

## 26. Software

The software development of RDA5856LE is support by RDA R-IOT SDK.

R-IoT is the IOT development platform of RDA, it composed of SDK, Eclipse IDE and some other auxiliary tools for debugging and audio calibration, etc. The SDK provides all the necessary components and standard APIs for the platform. The SDK is based on Eclipse which includes the cross-compile tools, connector to deploy and debug your software on the chip, basic library and sample code needed for embedded software development.

RDA has a variety of IoT chips for different requirements and scenarios. It has single bluetooth, WIFI chip; also it has SoC combined with bluetooth, WIFI and GSM for wireless network connection, and GPIO, I2C and etc. pins to connect sensor and peripheral device. What's more, RDA IoT chip supports co-exist technology which allows bluetooth and WIFI work simultaneously. Via HAL (hardware abstract layer) R-IoT provides the support of all RDA IoT chips.

Meanwhile, R-IoT offers "micro-services" style architecture to facilitate software development and maintenance. IoT applications are based on these "micro-services", for instance, if we build a bluetooth music player, we need to program with "BT micro-services". In most cases, these "micro-services" running in its own COS task and communicating with other services by sending or receiving COS event. The COS (Common OS) is an OS wrapper over C interface, it provides developers unified API so that developers could program with such interface without having to consider the native OS details.

Below is the diagram of R-IoT software architecture:

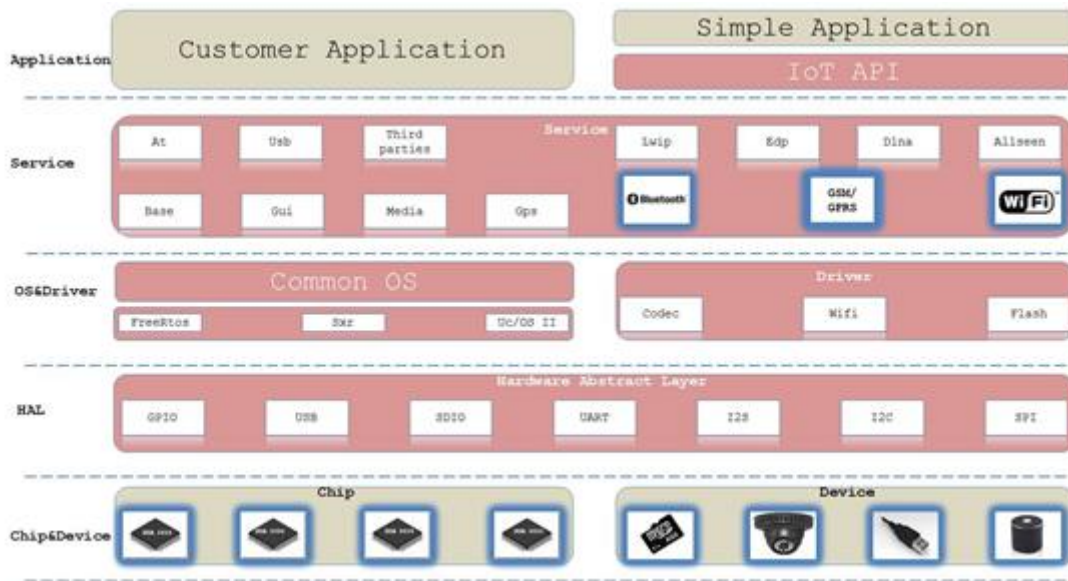

Figure 5 R-IoT Software Architecture

There are 5 layers:

- Chip and Device Layer
- HAL Layer

HAL is the module to configure chip and device; it tries to be common for all chips and devices, so the configuration must be very similar.

- OS and Driver Layer

R-IoT tries to support more OSES like RT-Thread, etc. without jeopardizing high layer service and application by introducing Common OS wrapper. Drivers are all external chip driver as opposed to chip drivers.

- Service Layer

These services are small building blocks, highly decoupled and provide user interface to application layer.

- Application Layer

In conclusion, R-IoT is almost a “turn-key” platform for IoT application development. The original SDK already had rich features for many mainstream IoT applications including home appliances and automation, asset tracking systems and consumer electronics devices, this enables the customer to rapid delivery its unique product to the market. Beyond that, its modularized and scalable software architecture makes it easier to support more OSES, chip, micro-services and cloud vendors, all these bring not only technical advantages but cost advantages as well.

For more information, please refer to RDA IOT SDK Development Manual and RDA IOT BT Development Manual.

## 27. Revision History

Revision	Date	Description
0.01	2016/05/13	Initial draft
0.02	2016/07/12	Add “Recommended Operation Conditions”