

## GLASS PASSIVATED BRIDGE RECTIFIERS

REVERSE VOLTAGE - 50 to 1000Volts  
FORWARD CURRENT - 8.0 Amperes

### FEATURES

- Surge overload rating -175 amperes peak
- Ideal for printed circuit board
- Reliable low cost construction utilizing molded plastic technique
- Plastic material has UL
- Mounting position: Any
- Mounting torque: 5 In. lb. Max

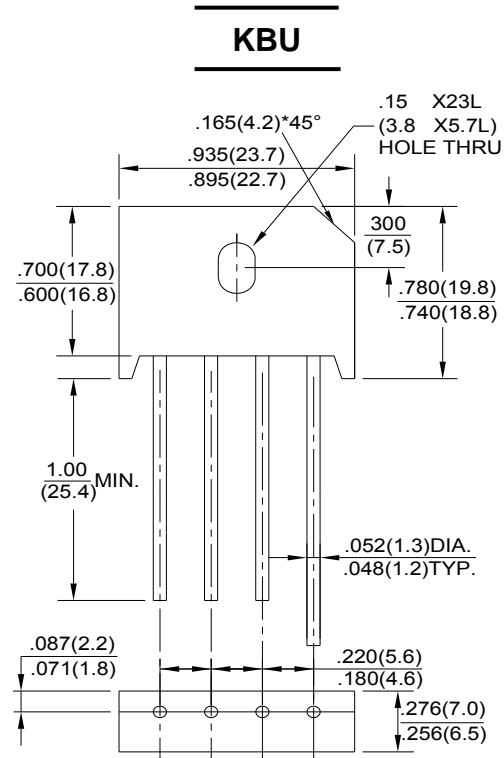

Dimensions in inches and (millimeters)

### MAXIMUM RATINGS AND ELECTRICAL CHARACTERISTICS

Rating at 25°C ambient temperature unless otherwise specified.

Single phase, half wave, 60Hz, resistive or inductive load.

For capacitive load, derate current by 20%

CHARACTERISTICS	SYMBOL	KBU 8005G	KBU 801G	KBU 802G	KBU 804G	KBU 806G	KBU 808G	KBU 810G	UNIT
Maximum Recurrent Peak Reverse Voltage	V <sub>RRM</sub>	50	100	200	400	600	800	1000	V
Maximum RMS Voltage	V <sub>RMS</sub>	35	70	140	280	420	560	700	V
Maximum DC Blocking Voltage	V <sub>DC</sub>	50	100	200	400	600	800	1000	V
Maximum Average Forward Rectified Output Current at T <sub>C</sub> =100°C	I <sub>(AV)</sub>	8.0							A
Peak Forward Surge Current 8.3ms single Half Sine-Wave Super Imposed on Rated Load (JEDEC Method)	I <sub>FSM</sub>	175							A
Maximum Instantaneous Forward Voltage Drop per Element at 4.0A	V <sub>F</sub>	1.1							V
Maximum Reverse Leakage at rated DC Blocking Voltage Per Element T <sub>J</sub> =25°C	I <sub>R</sub>	10							μA
Typical Junction Capacitance Per Element (Note1)	C <sub>J</sub>	250							pF
Operating Temperature Range	T <sub>J</sub>	-55 to +150							°C
Storage Temperature Range	T <sub>STG</sub>	-55 to +150							°C

NOTES: 1. Measured at 1.0MHz and applied reverse voltage of 4.0V DC.

2. The typical data above is for reference only (典型值仅供参考).

FIG.1-DERATING CURVE FOR  
 OUTPUT RECTIFIED CURRENT

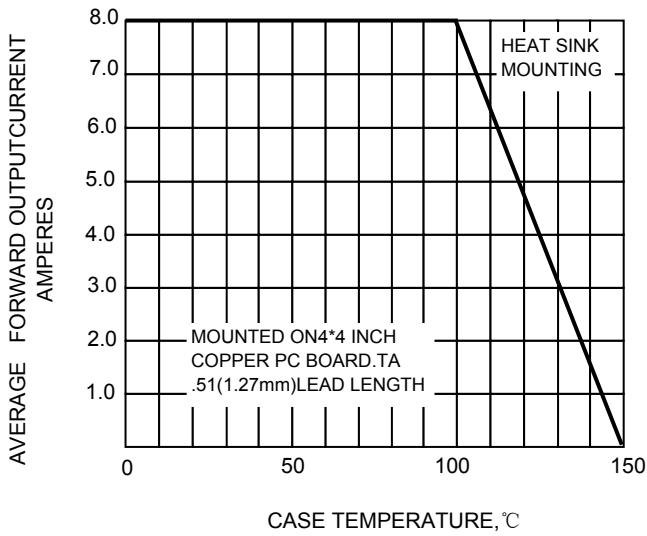

FIG.2 TYPICAL INSTANTANEOUS FORWARD  
 CHARACTERISTIC

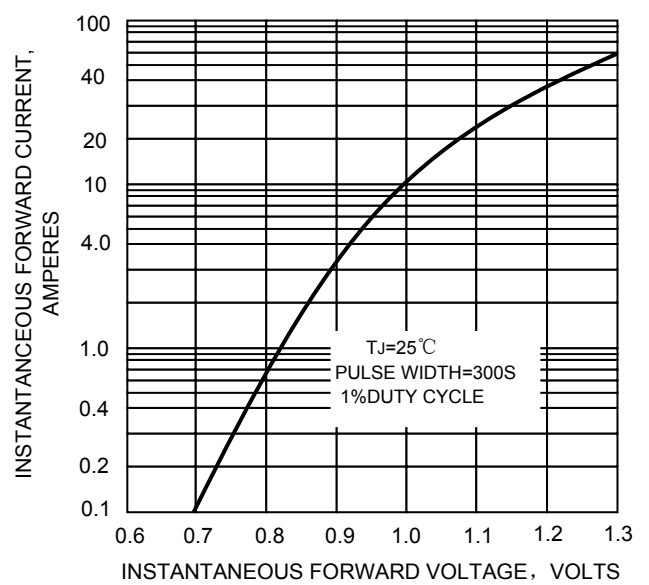

FIG.3-MAXIMUM NON-REPETITIVE PEAK  
 FORWARD SURGE CURRENT

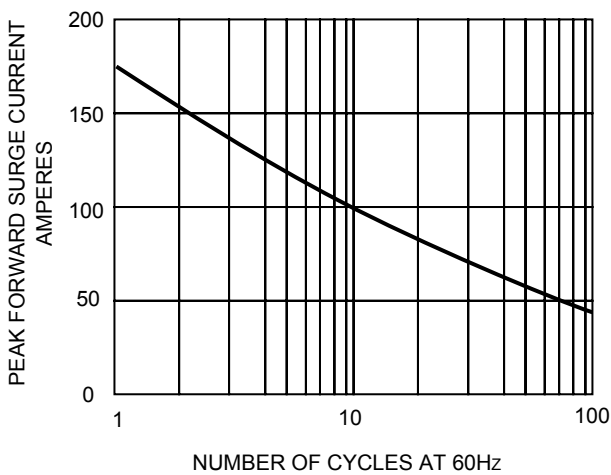

FIG.4-TYPICAL REVERSE  
 CHARACTERISTICS

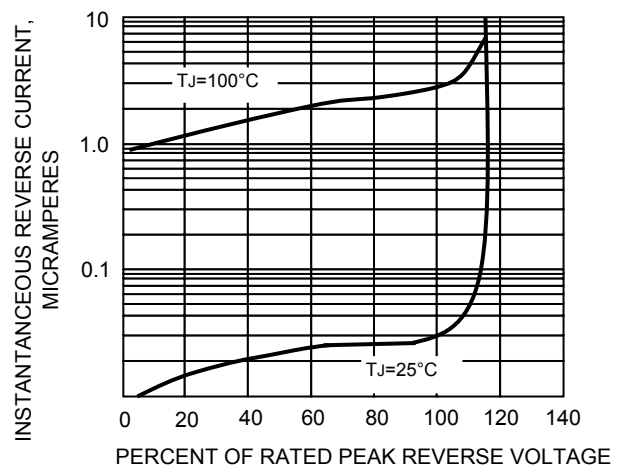
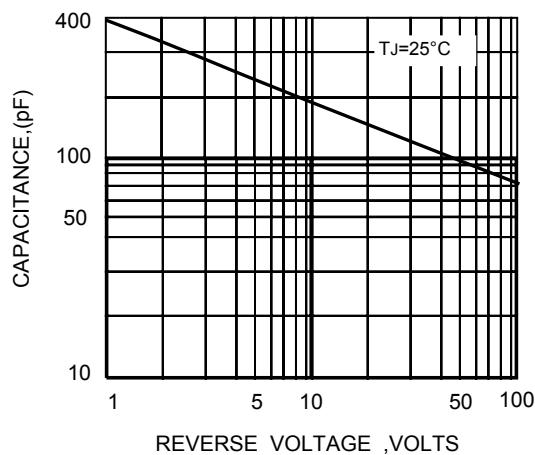

FIG.5-TYPICAL JUNCTION CAPACITANCE PER ELEMENT



The cruve graph is for reference only, can't be the basis for judgment(曲线图仅供参考)!