

规格书
Specification

品名
Model name

HND-1407B
C115184

PROPRIETARY
Huaneng Electronic co.,Ltd.

CONFIDENTIAL
Huaneng Electronic co.,Ltd.

Version #	Spec V1.0
制作日期 Date	2016/09/20
准备 Prepared	Yang shu yin Acoustic specialist,R&D Dept.
审核 Approved	Zhang chang hua Executive Manager,R&D Dept.



江苏华能电子有限公司

*Components Operating Div.
Huaneng Electronic co., Ltd.*

1.适用范围：本规范适用于HND-1407B蜂鸣器。

This specifications apply the HND-1407B buzzer.

2.基本规格/General specification

项目/Item	规格/Spec	条件/Condition
1 额定电压 Rated voltage	12VDC	
2 工作电压 Operation voltage	3~16VDC	
3 声压 Sound Pressure Level=SPL	≥85dB	测试环境：标准状态，标准驱动电路，额定电压 测试距离：0.1m Standard State,Standard Drive Circuit. Rated voltage,Distance at 0.1m
4 平均消费电流 Average consumption current	Max 12mA	
5 振荡频率 Oscillation frequency	4500±500Hz	
6 响应时间 Response time	Max 50mS	最低工作电压 Lowest operation voltage
7 工作温度范围 Range of operation temperature	-30~+80℃	声压 ≥85dB SPL ≥85dB
8 保存温度范围 Range of preservation temperature	-20~+80℃	
9 端子强度 Terminal strength	10N	拉负荷方向的终端轴 Pull load on the direction of the terminal axis
10 外部尺寸 Externals size	Φ14.1x7	参阅附图 Refer to the attached drawing
11 重量 Mass	2g	

☆标准状态：常温（15~35℃），湿度（25~95%相对湿度），空气压力（860~1060hpa）

在假设的情况判断，测试是一基本状态下进行。

Standard State:Ordinary Temp(15~95℃),Humidity(25~85%RH),Air pressure(860~1060hPa)

In case of doubtful judgment,the test is re-performed under Basic State.

☆基本情况：温度。（20±2℃），湿度（60~70%相对湿度），空气压力（860~1060hpa）

Basic State: Temp.(20±2℃),Humidity(60~70%RH),Air pressure(860~1060hPa)

<标准驱动电路>/<Standard Drive Circuit>

<标标测试治具>/<Standard Test Fixture>

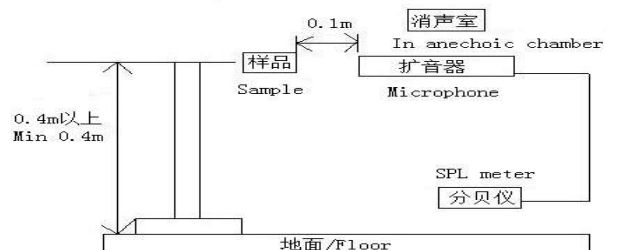
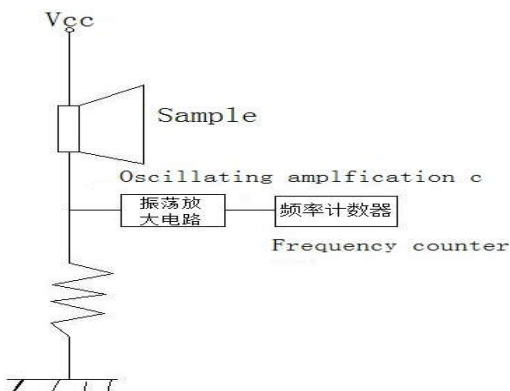

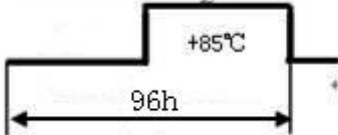
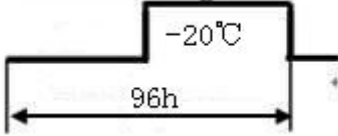
项目/Item	试验条件/Test condition	判断标准/Criteria	引用规格
1 高温保存试验 High temperature Preservation	+85℃环境下放置24小时 Exposure to +85℃ for 24 hrs.	经过测试,符合规格,没有任何不合格的外观和性能 After the test the part shall meet specifications without any degradation.	
2 低温保存试验 Low temperature preservation	-20℃环境下放置24小时 Exposure to -20℃ for 24 hrs.		
3 高温试验 High temperature Shock			
4 低温试验 Low temperature Shock			
5 常温寿命试验 Ordinary Temp. Life	常温(25℃±10℃)电压12VDC连续测试48小时 Driving the sounder at 12VDC for 48hrs in the room temperature(25℃±10℃)		
6 高温寿命试验 High Temp. Life	高温(+85℃)电压12VDC连续测试2小时 Driving the sounder at 12VDC for 2hrs in the low temperature(+85℃)		
7 低温寿命试验 Low Temp. Life	低温(-20℃)电压12VDC连续测试2小时 Driving the sounder at 12VDC for 2hrs in the low temperature(-20℃)		
8 端子拉力试验 Lead strength	10N的拉力在端子上拉10±1秒 Pull load on the direction of the terminal axis for 10±1 sec.		
9 跌落试验 Free drop	70cm高自由掉落到厚40mm的木板上,每个方向一次 Free drop, 70cm height, on wood board (t40mm) X, Y, Z 3Direction 1time each, total 3times.		
10 端子可焊性试验 Solderability	260±5℃焊接温度。时间: 5±0.5sec。 Temp. 260±5℃ Soaking Time: 5±0.5sec	端子95%必须覆盖着焊料 95% surface of lead pins must be covered with fresh solder and no soldering holes should be found	

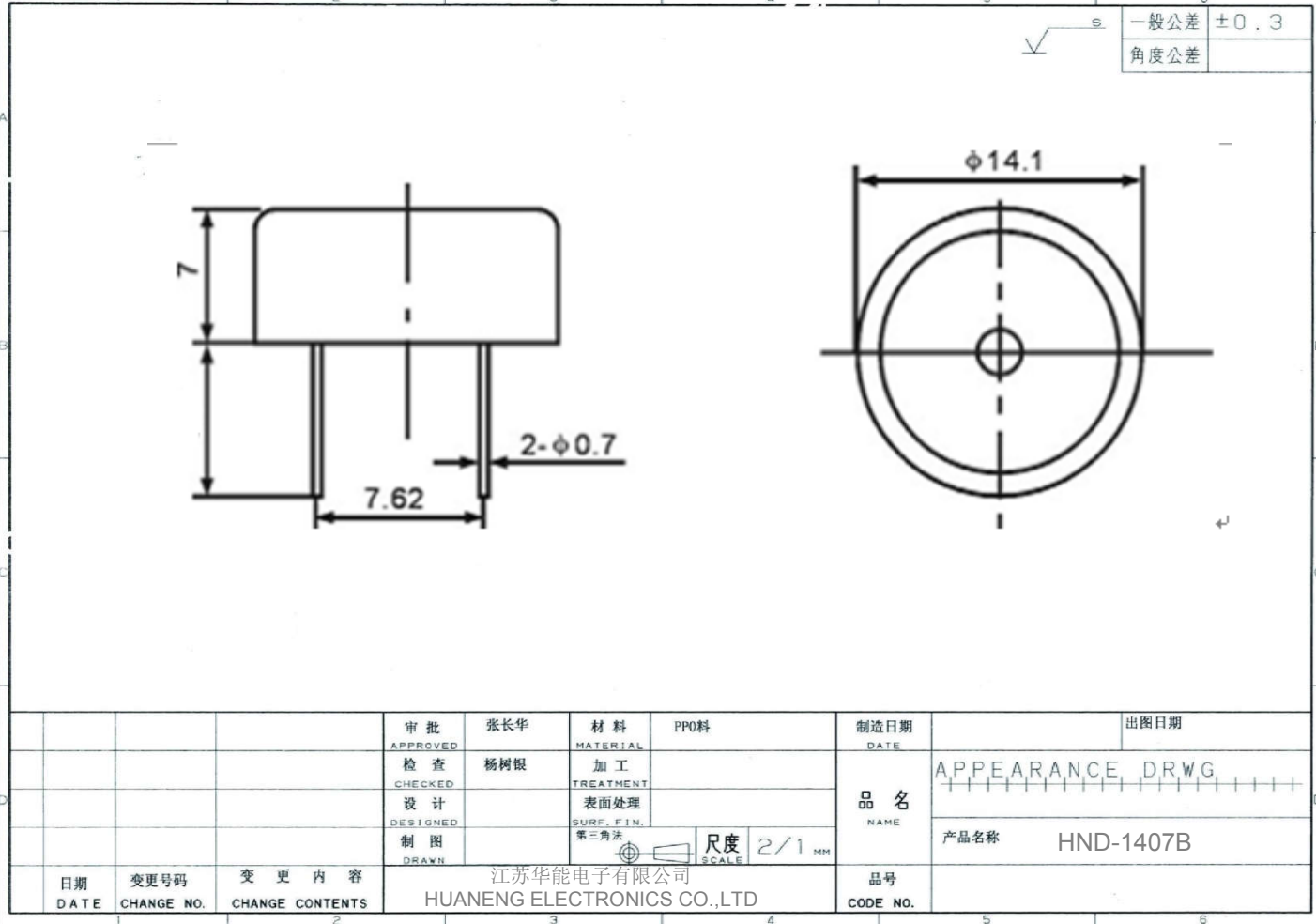

产品频率图

