

### Features

- Single-Supply Operation from +2.1V ~ +5.5V
- Rail-to-Rail Input / Output
- Gain-Bandwidth Product: 1.5MHz (Typ. @25°C)
- Low Input Bias Current: 20pA (Typ. @25°C)
- Low Offset Voltage: 5uV (Max. @25°C)
- Quiescent Current: 320µA per Amplifier (Typ.)
- Operating Temperature: -40°C ~ +125°C
- Zero Drift: 0.05µV/°C (Max.)
- Embedded RF Anti-EMI Filter
- Small Package:
  - GS8551 Available in SOT23-5 and SOP-8 Packages
  - GS8552 Available in MSOP-8 and SOP-8 Packages

### General Description

The GS855X amplifier is single/dual supply, micro-power, zero-drift CMOS operational amplifiers, the amplifiers offer bandwidth of 1.5MHz, rail-to-rail inputs and outputs, and single-supply operation from 2.1V to 5.5V. GS855X uses chopper stabilized technique to provide very low offset voltage (less than 5µV maximum) and near zero drift over temperature. Low quiescent supply current of 320µA per amplifier and very low input bias current of 20pA make the devices an ideal choice for low offset, low power consumption and high impedance applications. The GS855X offers excellent CMRR without the crossover associated with traditional complementary input stages. This design results in superior performance for driving analog-to-digital converters (ADCs) without degradation of differential linearity.

The GS8551 is available in SOT23-5 and SOP8 packages. And the GS8552 is available in MSOP8 and SOP8 packages. The extended temperature range of -40°C to +125°C over all supply voltages offers additional design flexibility.

### Applications

- Transducer Application
- Temperature Measurements
- Electronics Scales
- Handheld Test Equipment
- Battery-Powered Instrumentation

### Pin Configuration

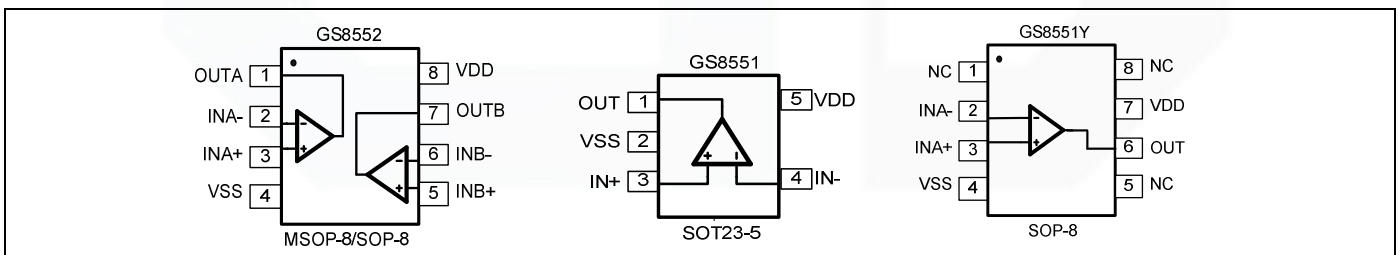

Figure 1. Pin Assignment Diagram

## Absolute Maximum Ratings

Condition	Min	Max
Power Supply Voltage ( $V_{DD}$ to $V_{SS}$ )	-0.5V	+7.5V
Analog Input Voltage ( $IN+$ or $IN-$ )	$V_{SS}-0.5V$	$V_{DD}+0.5V$
PDB Input Voltage	$V_{SS}-0.5V$	+7V
Operating Temperature Range	-40°C	+125°C
Junction Temperature	+160°C	
Storage Temperature Range	-55°C	+150°C
Lead Temperature (soldering, 10sec)	+260°C	
<b>Package Thermal Resistance (<math>T_A=+25^\circ\text{C}</math>)</b>		
SOP-8, $\theta_{JA}$	125°C/W	
MSOP-8, $\theta_{JA}$	216°C/W	
SOT23-5, $\theta_{JA}$	190°C/W	
<b>ESD Susceptibility</b>		
HBM	6KV	
MM	400V	

**Note:** Stress greater than those listed under Absolute Maximum Ratings may cause permanent damage to the device. This is a stress rating only and functional operation of the device at these or any other conditions outside those indicated in the operational sections of this specification are not implied. Exposure to absolute maximum rating conditions for extended periods may affect reliability.

## Package/Ordering Information

MODEL	CHANNEL	ORDER NUMBER	PACKAGE DESCRIPTION	PACKAGE OPTION	MARKING INFORMATION
GS8551	Single	GS8551-TR	SOT23-5	Tape and Reel,3000	8551
		GS8551Y-SR	SOP-8	Tape and Reel,2500	GS8551Y
GS8552	Dual	GS8552-SR	SOP-8	Tape and Reel,2500	GS8552
		GS8552-MR	MSOP-8	Tape and Reel,3000	GS8552

## Electrical Characteristics

( $V_S = +5V$ ,  $V_{CM} = +2.5V$ ,  $V_O = +2.5V$ ,  $T_A = +25^\circ C$ , unless otherwise noted.)

PARAMETER	CONDITIONS	MIN	TYP	MAX	UNITS
<b>INPUT CHARACTERISTICS</b>					
Input Offset Voltage ( $V_{OS}$ )			1	5	$\mu V$
Input Bias Current ( $I_B$ )			20		pA
Input Offset Current ( $I_{OS}$ )			10		pA
Common-Mode Rejection Ratio (CMRR)	$V_{CM} = 0V$ to $5V$		110		dB
Large Signal Voltage Gain ( $A_{VO}$ )	$R_L = 10k\Omega$ , $V_O = 0.3V$ to $4.7V$		145		dB
Input Offset Voltage Drift ( $\Delta V_{OS}/\Delta T$ )			50		nV/ $^\circ C$
<b>OUTPUT CHARACTERISTICS</b>					
Output Voltage High ( $V_{OH}$ )	$R_L = 100k\Omega$ to $-V_S$		4.998		V
	$R_L = 10k\Omega$ to $-V_S$		4.994		V
Output Voltage Low ( $V_{OL}$ )	$R_L = 100k\Omega$ to $+V_S$		2		mV
	$R_L = 10k\Omega$ to $+V_S$		5		mV
Short Circuit Limit ( $I_{SC}$ )	$R_L = 10\Omega$ to $-V_S$		43		mA
Output Current ( $I_O$ )			30		mA
<b>POWER SUPPLY</b>					
Power Supply Rejection Ratio (PSRR)	$V_S = 2.5V$ to $5.5V$		115		dB
Quiescent Current ( $I_Q$ )	$V_O = 0V$ , $R_L = 0\Omega$		320		$\mu A$
<b>DYNAMIC PERFORMANCE</b>					
Gain-Bandwidth Product (GBP)	$G = +100$		1.5		MHz
Slew Rate (SR)	$R_L = 10k\Omega$		0.84		V/ $\mu s$
Overload Recovery Time			0.10		ms
<b>NOISE PERFORMANCE</b>					
Voltage Noise ( $e_n$ p-p)	0Hz to 10Hz		0.81		$\mu V_{P-P}$
Voltage Noise Density ( $e_n$ )	$f = 1kHz$		49		nV/ $\sqrt{Hz}$

**Typical Performance characteristics**

Large Signal Transient Response at +5V

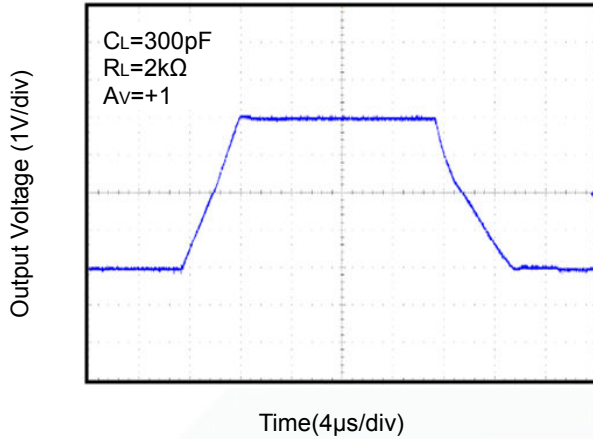

Large Signal Transient Response at +2.5V

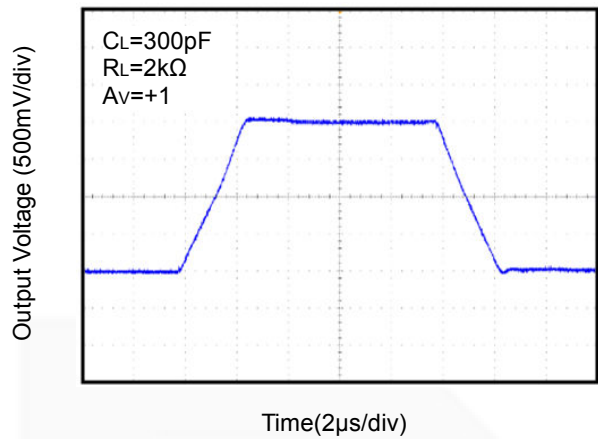

Small Signal Transient Response at +5V

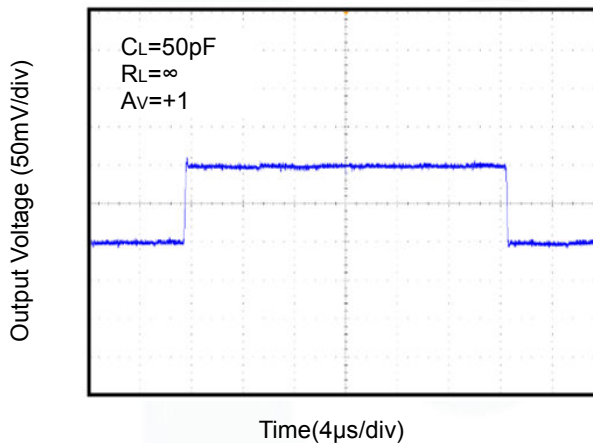

Small Signal Transient Response at +2.5V

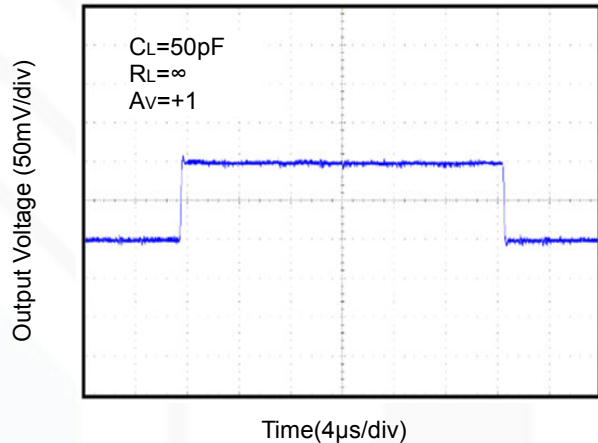

Closed Loop Gain vs. Frequency at +5V

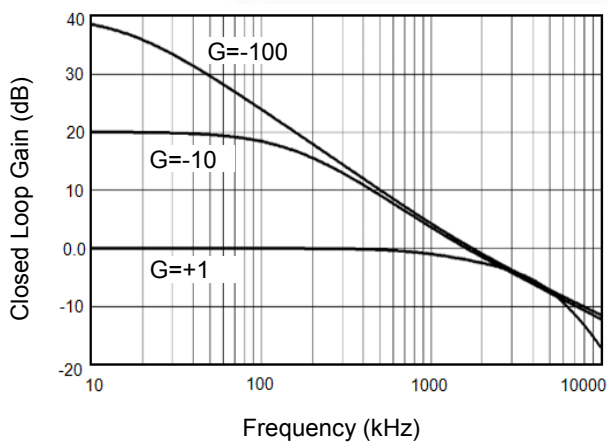

Closed Loop Gain vs. Frequency at +2.5V

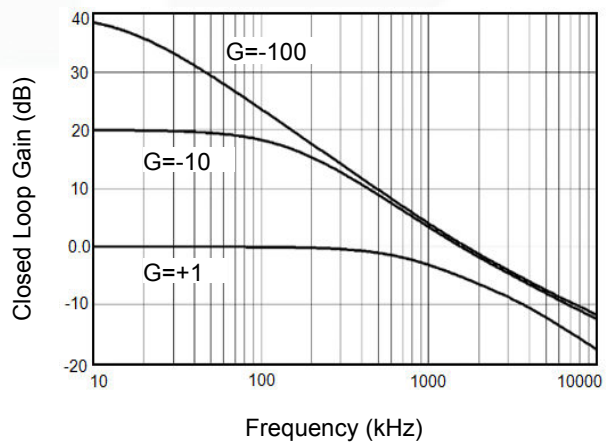

**Typical Performance characteristics**

Open Loop Gain, Phase Shift vs. Frequency at +5V

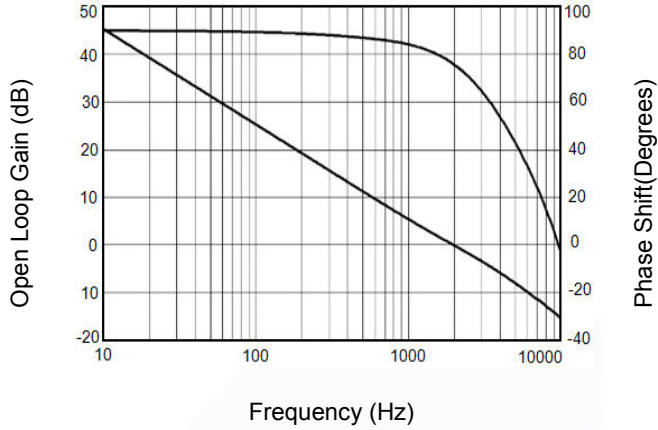

Open Loop Gain, Phase Shift vs. Frequency at +2.5V

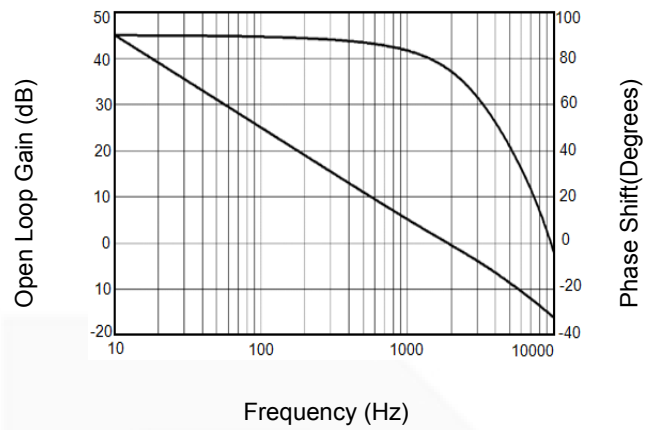

Positive Overvoltage Recovery

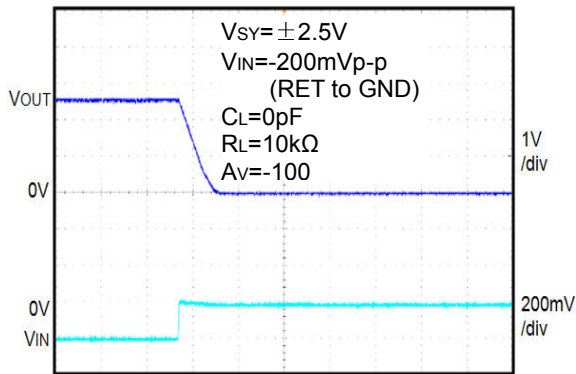

Time (4µs/div)

Negative Overvoltage Recovery

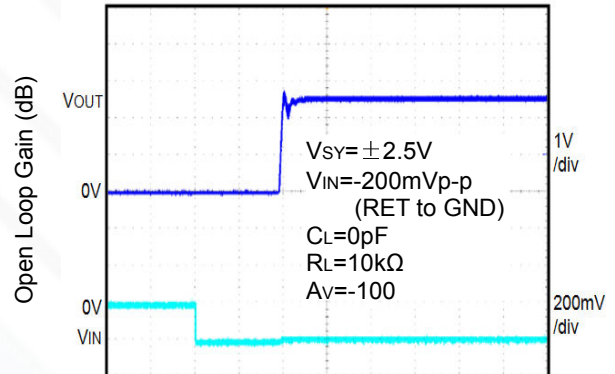

Time (40µs/div)

0.1Hz to 10Hz Noise at +5V

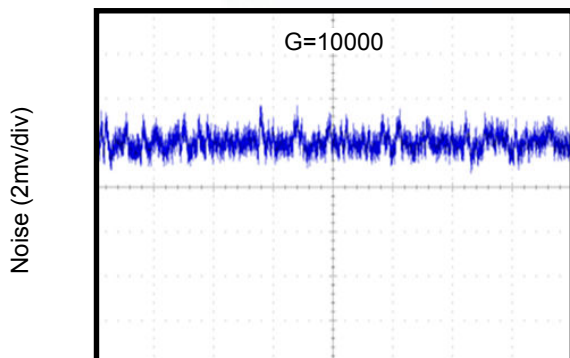

Time (10s/div)

0.1Hz to 10Hz Noise at +2.5V

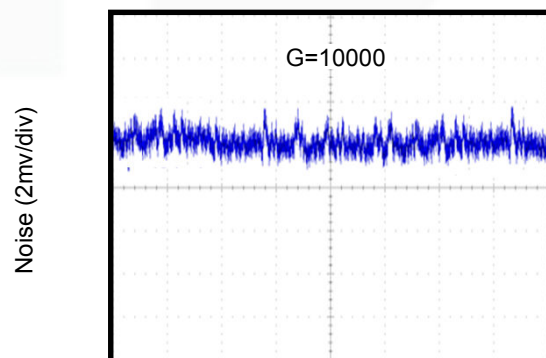

Time (10s/div)

## Application Note

### Size

GS855X series op amps are unity-gain stable and suitable for a wide range of general-purpose applications. The small footprints of the GS855X series packages save space on printed circuit boards and enable the design of smaller electronic products.

### Power Supply Bypassing and Board Layout

GS855X series operates from a single 2.1V to 5.5V supply or dual  $\pm 1.05\text{V}$  to  $\pm 2.75\text{V}$  supplies. For best performance, a  $0.1\mu\text{F}$  ceramic capacitor should be placed close to the  $V_{\text{DD}}$  pin in single supply operation. For dual supply operation, both  $V_{\text{DD}}$  and  $V_{\text{SS}}$  supplies should be bypassed to ground with separate  $0.1\mu\text{F}$  ceramic capacitors.

### Low Supply Current

The low supply current (typical  $320\mu\text{A}$  per channel) of GS855X series will help to maximize battery life. They are ideal for battery powered systems

### Operating Voltage

GS855X series operate under wide input supply voltage (2.1V to 5.5V). In addition, all temperature specifications apply from  $-40^\circ\text{C}$  to  $+125^\circ\text{C}$ . Most behavior remains unchanged throughout the full operating voltage range. These guarantees ensure operation throughout the single Li-Ion battery lifetime

### Rail-to-Rail Input

The input common-mode range of GS855X series extends  $100\text{mV}$  beyond the supply rails ( $V_{\text{SS}}-0.1\text{V}$  to  $V_{\text{DD}}+0.1\text{V}$ ). This is achieved by using complementary input stage. For normal operation, inputs should be limited to this range.

### Rail-to-Rail Output

Rail-to-Rail output swing provides maximum possible dynamic range at the output. This is particularly important when operating in low supply voltages. The output voltage of GS855X series can typically swing to less than  $5\text{mV}$  from supply rail in light resistive loads ( $>100\text{k}\Omega$ ), and  $60\text{mV}$  of supply rail in moderate resistive loads ( $10\text{k}\Omega$ ).

### Capacitive Load Tolerance

The GS855x family is optimized for bandwidth and speed, not for driving capacitive loads. Output capacitance will create a pole in the amplifier's feedback path, leading to excessive peaking and potential oscillation. If dealing with load capacitance is a requirement of the application, the two strategies to consider are (1) using a small resistor in series with the amplifier's output and the load capacitance and (2) reducing the bandwidth of the amplifier's feedback loop by increasing the overall noise gain. Figure 2. shows a unity gain follower using the series resistor strategy. The resistor isolates the output from the capacitance and, more importantly, creates a zero in the feedback path that compensates for the pole created by the output capacitance.

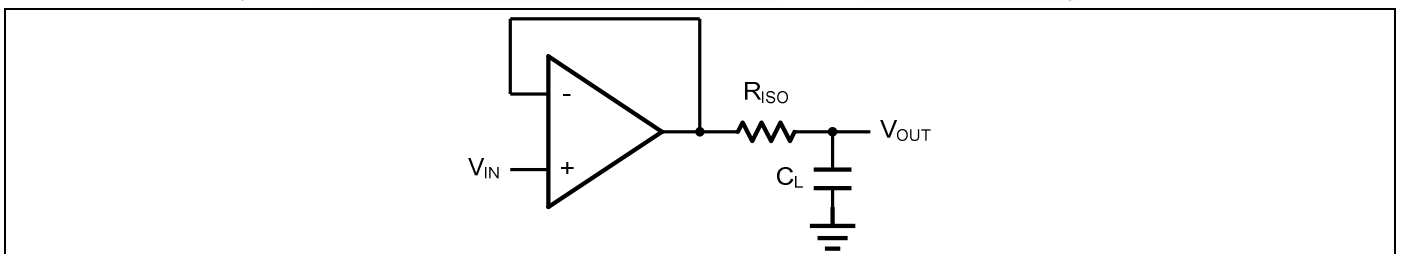

Figure 2. Indirectly Driving a Capacitive Load Using Isolation Resistor

The bigger the  $R_{\text{ISO}}$  resistor value, the more stable  $V_{\text{OUT}}$  will be. However, if there is a resistive load  $R_{\text{L}}$  in parallel with the capacitive load, a voltage divider (proportional to  $R_{\text{ISO}}/R_{\text{L}}$ ) is formed, this will result in a gain error.

The circuit in Figure 3 is an improvement to the one in Figure 2.  $R_{\text{F}}$  provides the DC accuracy by feed-forward the  $V_{\text{IN}}$  to  $R_{\text{L}}$ .  $C_{\text{F}}$

and  $R_{ISO}$  serve to counteract the loss of phase margin by feeding the high frequency component of the output signal back to the amplifier's inverting input, thereby preserving the phase margin in the overall feedback loop. Capacitive drive can be increased by increasing the value of  $C_F$ . This in turn will slow down the pulse response.

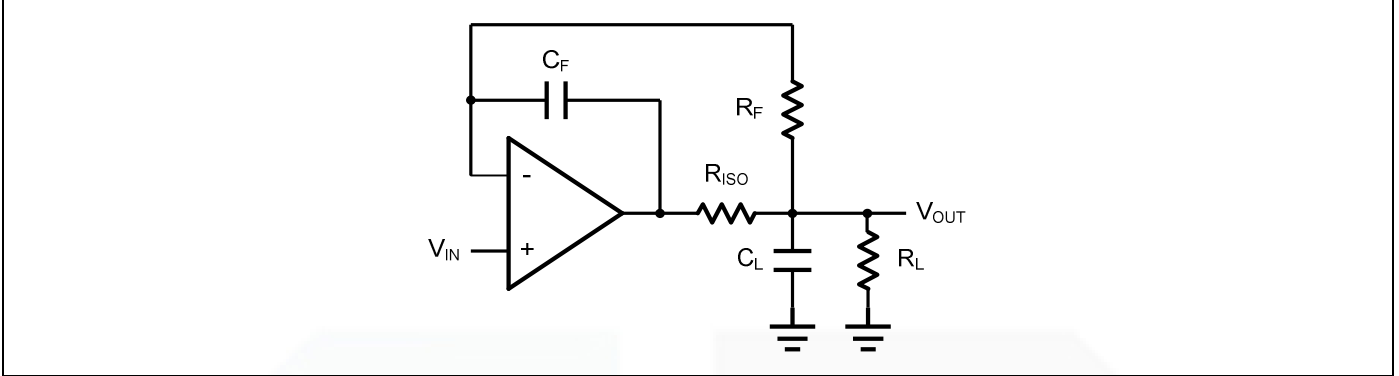

Figure 3. Indirectly Driving a Capacitive Load with DC Accuracy

## Typical Application Circuits

### Differential amplifier

The differential amplifier allows the subtraction of two input voltages or cancellation of a signal common to the two inputs. It is useful as a computational amplifier in making a differential to single-end conversion or in rejecting a common mode signal. Figure 4. shows the differential amplifier using GS855X.

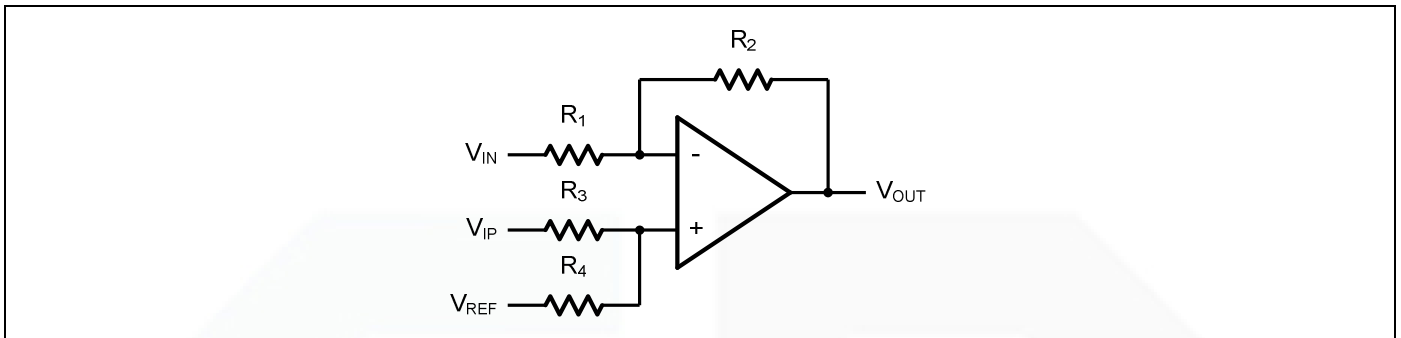

Figure 4. Differential Amplifier

$$V_{OUT} = \left( \frac{R_1 + R_2}{R_3 + R_4} \right) \frac{R_4}{R_1} V_{IN} - \frac{R_2}{R_1} V_{IP} + \left( \frac{R_1 + R_2}{R_3 + R_4} \right) \frac{R_3}{R_1} V_{REF}$$

If the resistor ratios are equal (i.e.  $R_1 = R_3$  and  $R_2 = R_4$ ), then

$$V_{OUT} = \frac{R_2}{R_1} (V_{IP} - V_{IN}) + V_{REF}$$

### Low Pass Active Filter

The low pass active filter is shown in Figure 5. The DC gain is defined by  $-R_2/R_1$ . The filter has a -20dB/decade roll-off after its corner frequency  $f_c = 1/(2\pi R_3 C_1)$ .

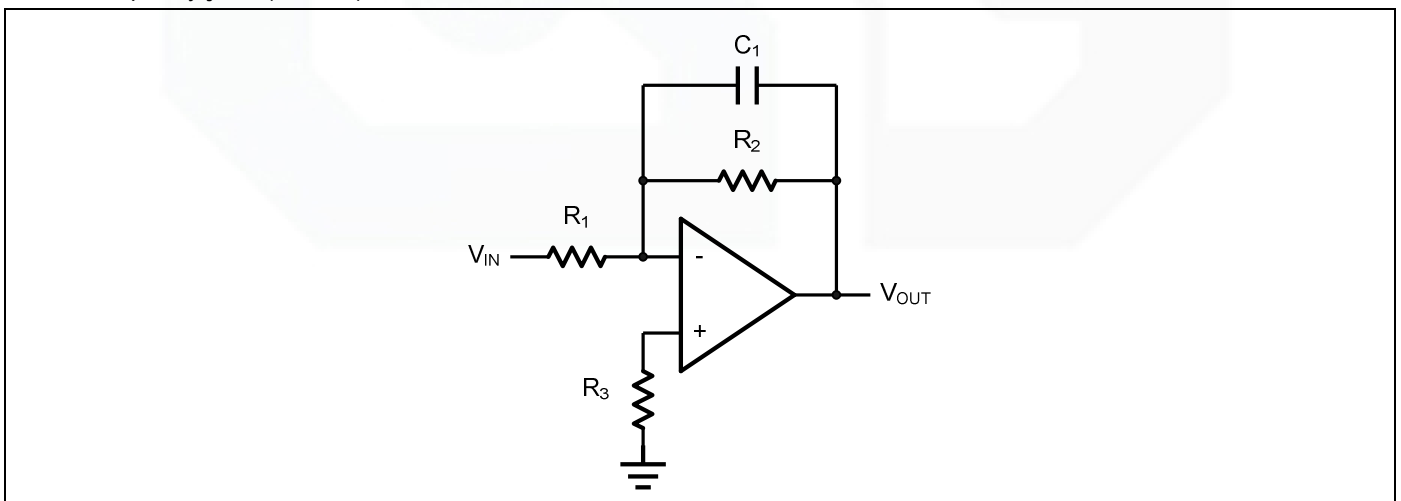

Figure 5. Low Pass Active Filter



### Instrumentation Amplifier

The triple GS855X can be used to build a three-op-amp instrumentation amplifier as shown in Figure 6. The amplifier in Figure 6 is a high input impedance differential amplifier with gain of  $R_2/R_1$ . The two differential voltage followers assure the high input impedance of the amplifier.

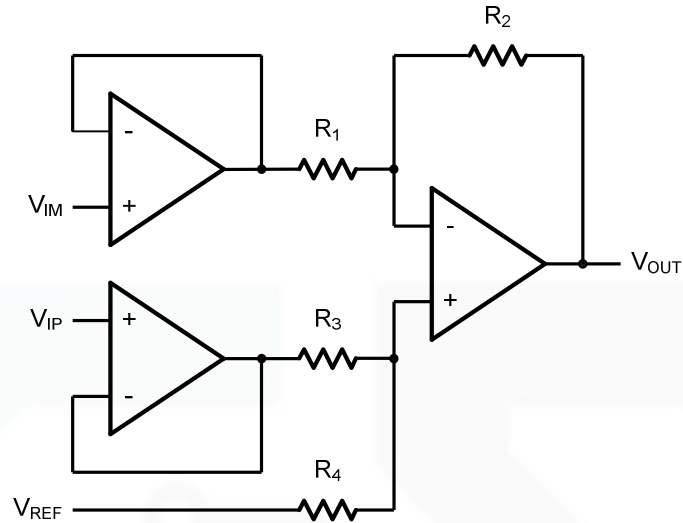
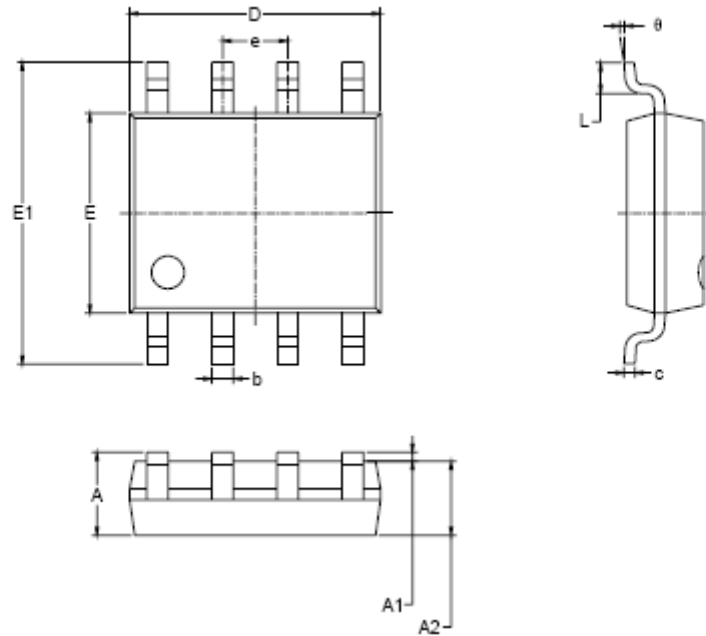
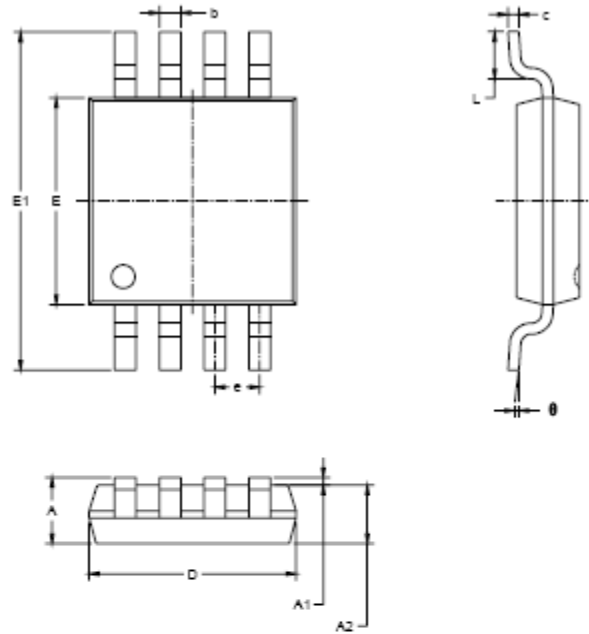

Figure 6. Instrument Amplifier

**Package Information**
**SOP-8**

Symbol	Dimensions In Millimeters		Dimensions In Inches	
	MIN	MAX	MIN	MAX
A	1.350	1.750	0.053	0.069
A1	0.100	0.250	0.004	0.010
A2	1.350	1.550	0.053	0.061
b	0.330	0.510	0.013	0.020
c	0.170	0.250	0.006	0.010
D	4.700	5.100	0.185	0.200
E	3.800	4.000	0.150	0.157
E1	5.800	6.200	0.228	0.244
e	1.27 BSC		0.050 BSC	
L	0.400	1.270	0.016	0.050
θ	0°	8°	0°	8°

**MSOP-8**

Symbol	Dimensions In Millimeters		Dimensions In Inches	
	MIN	MAX	MIN	MAX
A	0.820	1.100	0.032	0.043
A1	0.020	0.150	0.001	0.006
A2	0.750	0.950	0.030	0.037
b	0.250	0.380	0.010	0.015
c	0.090	0.230	0.004	0.009
D	2.900	3.100	0.114	0.122
E	2.900	3.100	0.114	0.122
E1	4.750	5.050	0.187	0.199
e	0.650 BSC		0.026 BSC	
L	0.400	0.800	0.016	0.031
θ	0°	6°	0°	6°

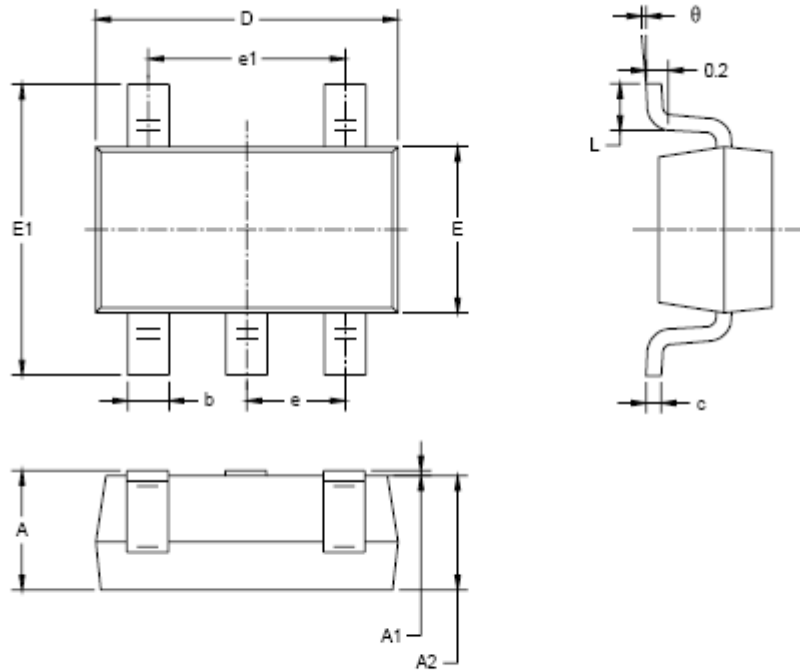
**SOT23-5**

Symbol	Dimensions In Millimeters		Dimensions In Inches	
	MIN	MAX	MIN	MAX
A	1.050	1.250	0.041	0.049
A1	0.000	0.100	0.000	0.004
A2	1.050	1.150	0.041	0.045
b	0.300	0.500	0.012	0.020
c	0.100	0.200	0.004	0.008
D	2.820	3.020	0.111	0.119
E	1.500	1.700	0.059	0.067
E1	2.650	2.950	0.104	0.118
e	0.950 BSC		0.037 BSC	
e1	1.900 BSC		0.075 BSC	
L	0.300	0.600	0.012	0.024
$\theta$	0°	8°	0°	8°