

Low-Power Hall Switch



General Description

FD2H001B is a low-power integrated Hall switch designed to sense the applied magnetic flux density and give a digital output, which indicates the present condition of the magnitude sensed. One example of the applications is the on/off switch in cellular flip-phones.

The micro power design is especially suitable for battery-operated systems such as cellular phones or laptop computers, in which power consumption is one major concern. The typical power consumption of FD2H001B is below 10 μ W at 2.7V.

The magnetic switching points are precise and insensitive to process and temperature variations.

For FD2H001B, the output will be at the "low" level if the applied magnetic flux density(North pole) is stronger than the switching threshold.

For detailed magnetic flux direction please refer to the figure.3

Features

- Micro power consumption
- 2.4V to 5.5V battery operation
- Chopper Amplifier based design:
Insensitive to noise and offset caused by process variations, operating temperatures and mechanical stress
- Digital output
- Programmable output direction
- CMOS process
- Available in SOT23 / SIP3 package

Pin Descriptions

FD2H001BY/SOT23

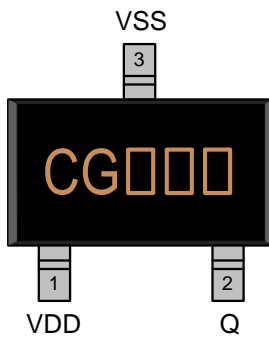

Name	I/O	Description
VDD	P	Positive supply
Q	O	Open Drain output
VSS	G	Ground

Legend: I=input, O=output, I/O=input/output, P=power supply, G=ground

FD2H001BH/SIP3

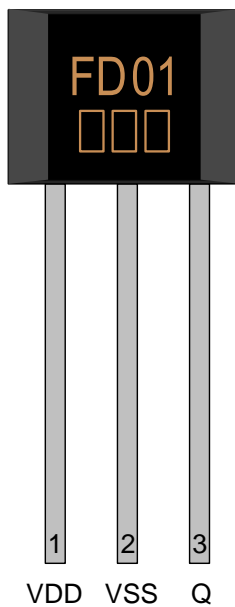

Marking Information

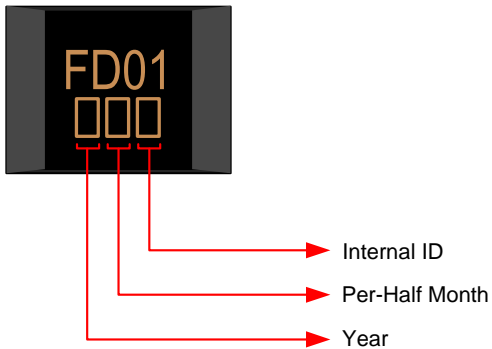
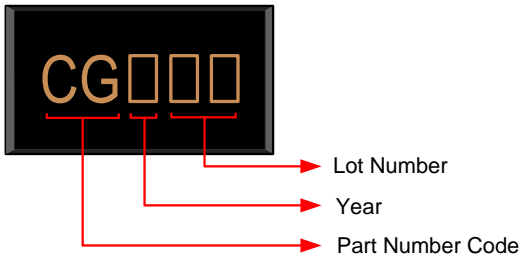

Lot Number: Wafer lot number's last two digits

For Example: XX686 → 86

Year: Production year's last digit

Internal ID: Internal Identification Code

Part Number Code: Part number identification code for this product.

Block Diagram

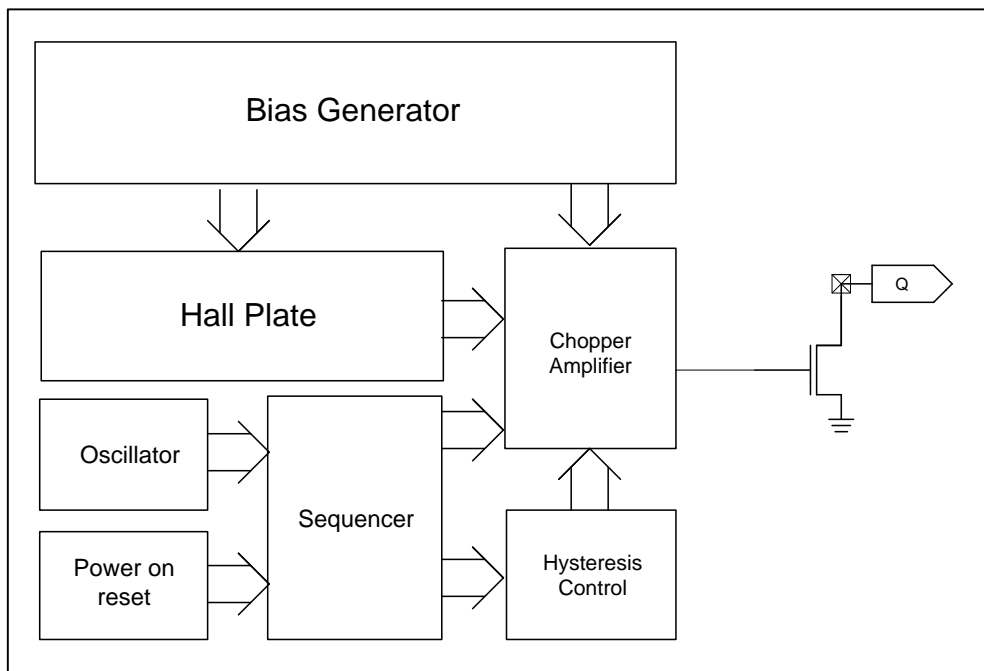

Figure.1

Functional Descriptions

Refer to the block diagram (Figure.1), FD2H001B is composed of the following building blocks:

- Bias generator

The bias generator provides precise, temperature and process insensitive current sources for both the Hall plate and the chopper amplifier. These current sources in turn guarantee proper operation of the chip and precise switching thresholds under all kinds of environments specified in the specification.

- Oscillator + Sequencer

The built-in oscillator provides the clock signal, which is taken by the sequencer to determine the periods of the operating phase and the stand-by phase. Typically the operating time is about 60us and the stand-by time is 150ms. Using such a clocking scheme, the average power consumption is almost equal to that in the stand-by phase, which is under 10μW at 2.7V.

- Power on Reset

Used to detect the power-up ramp and reset the digital circuits to attain correct operation as soon as the power is ready.

- Chopper Amplifier

To achieve a higher resolution the chopper amplifier structure is adopted in this design. Use of this structure dynamically removes both the offset and flicker noise at the same time.

- Hysteresis Control

This block determines the switching threshold of the Hall switch in different situations.

Ordering information

Part Number	Operating Temperature	Package	Description	MOQ
FD2H001BYR-G1	-20 °C to +105 °C	SOT23	±50G (B)	3,000ea / Reel
FD2H001BH-G1	20 °C to +105 °C	SIP3	±50G (B)	1,000ea / Bag

Absolute Maximum Ratings

Parameter	Conditions	Values		Unit
		min.	max.	
Ambient Operating Temperature	-	-40	85	°C
Storage Temperature	-	-40	150	°C
DC Supply Voltage	-	2.4	5.5	V
Supply Current	-	-	2.5	mA
Magnetic Flux Density	-		unlimited	Gauss
Lead Temperature	10sec	-	260	°C

IR Re-flow Soldering Curve

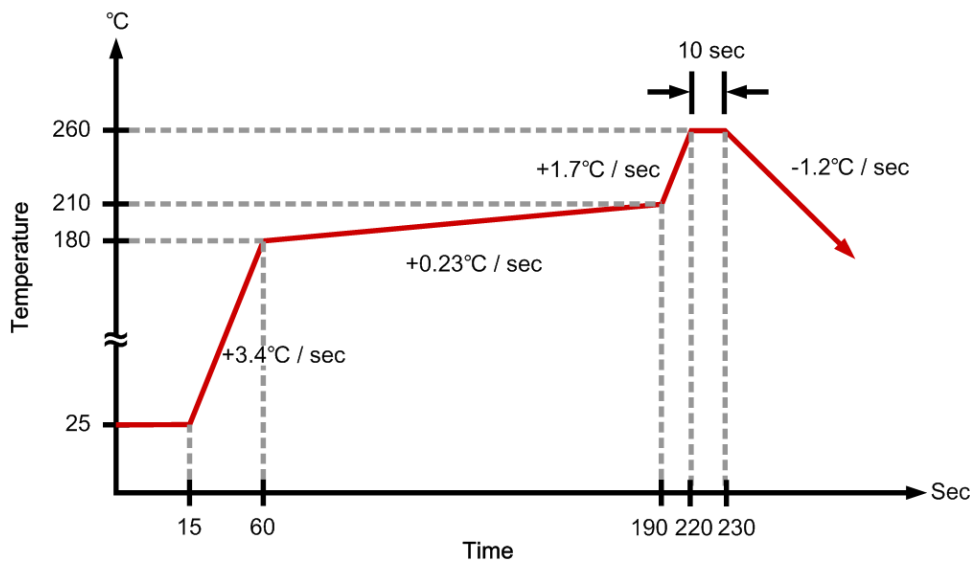

Figure. 2

This datasheet contains new product information. Feeling Technology reserves the rights to modify the product specification without notice. No liability is assumed as a result of the use of this product. No rights under any patent accompany the sales of the product.

Operating Conditions

Parameter	Conditions	Min.	Typ.	Max.	Unit
Supply Voltage	-	2.4	2.7	5.5	V
Output Voltage	-	-0.3	2.7	5.5	V
Ambient Temperature	-	-40	25	85	°C

Electrical Characteristics

Parameter	Conditions	Min.	Typ.	Max.	Unit
Average Supply Current	-	-	3 ¹	20	μA
Average Supply Current (operating phase)	-	-	1.1 ¹	-	mA
Average Supply Current (stand-by phase)	-	-	2.5 ¹	-	μA
Output Saturation Voltage	-	-	0.1	-	V
Output Leakage Current	-	-	0.01	-	μA
Operating time	-	-	60	-	μs
Standby time	-	-	150	-	ms
Duty cycle	-	-	0.04	-	%

1. operating voltage 2.7V

Magnetic Characteristics

Parameter	Conditions	Min.	Typ.	Max.	Unit
Operate Points (B _{OP})	-	40	50	60	G
Hysteresis	-	5	10	15	G

Magnetic Flux Direction

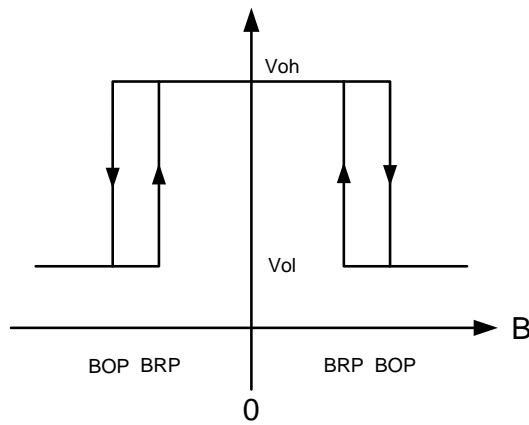
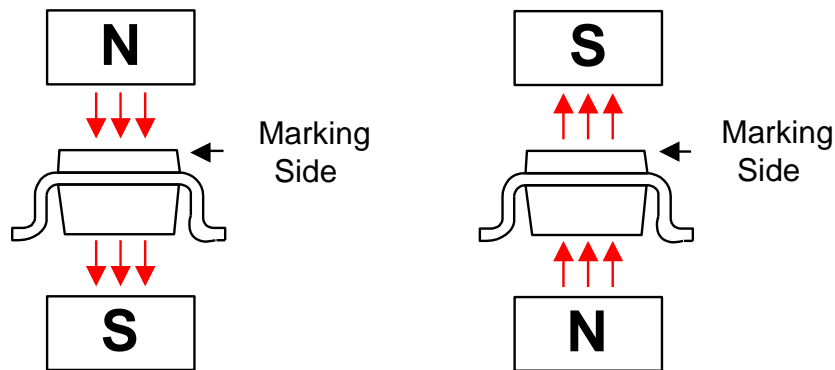

Figure. 3

Typical Characteristics (Example : FD2H001B)

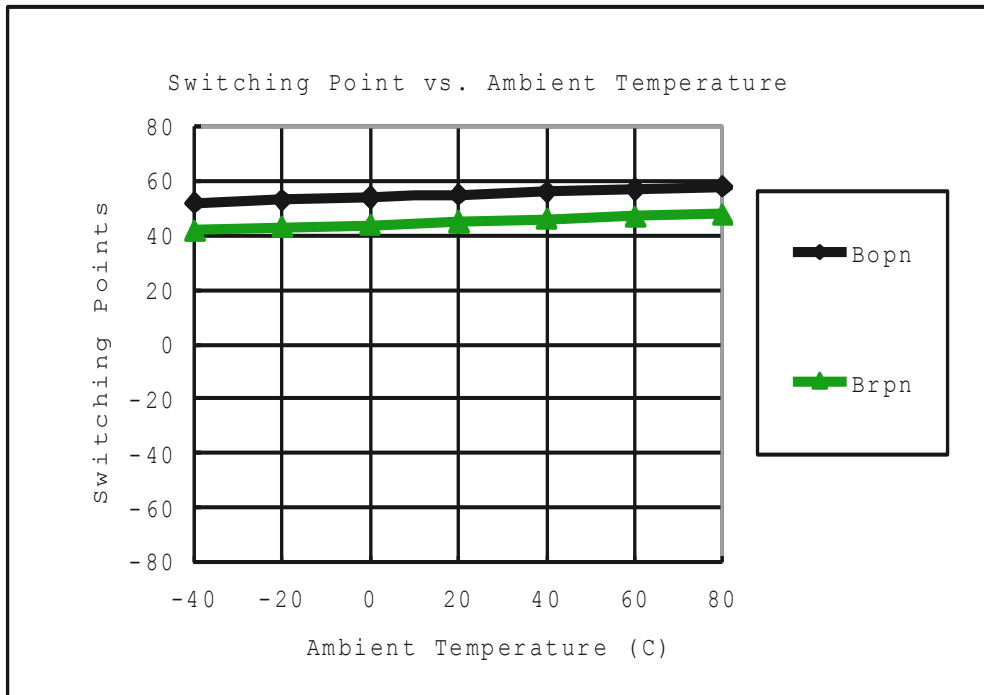

Figure.4 Magnetic Switch Points Versus Ambient Temperature (VDD=2.7V)

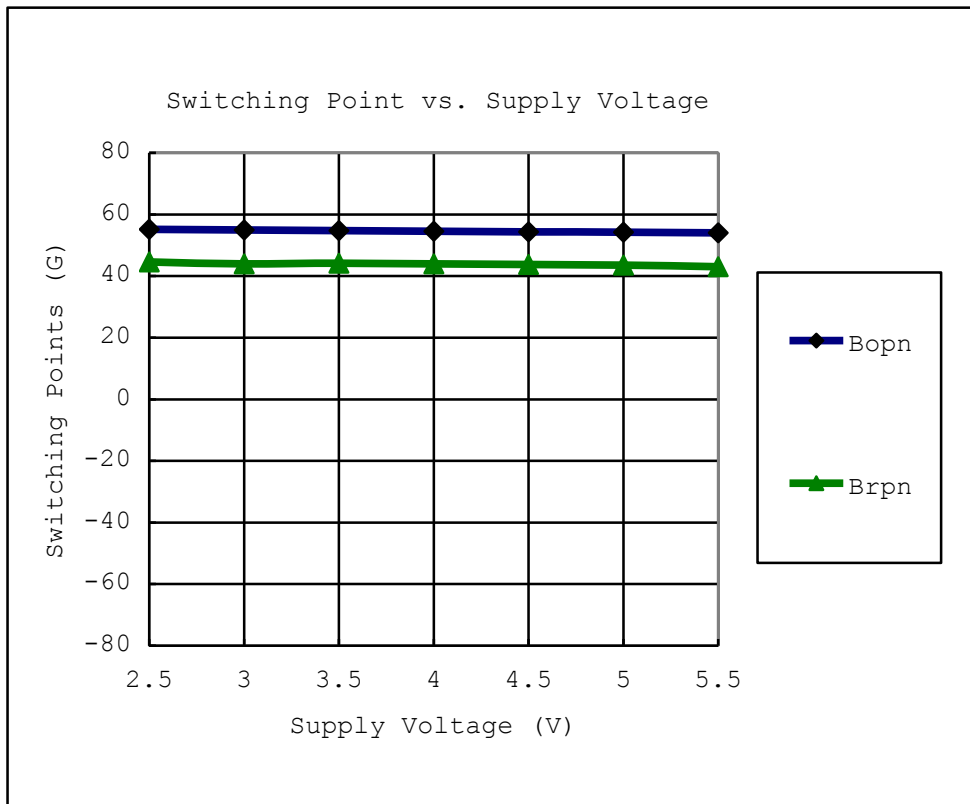

Figure.5 Magnetic Switch Points Versus Supply Voltage (Ta=25C degree)

This datasheet contains new product information. Feeling Technology reserves the rights to modify the product specification without notice. No liability is assumed as a result of the use of this product. No rights under any patent accompany the sales of the product.

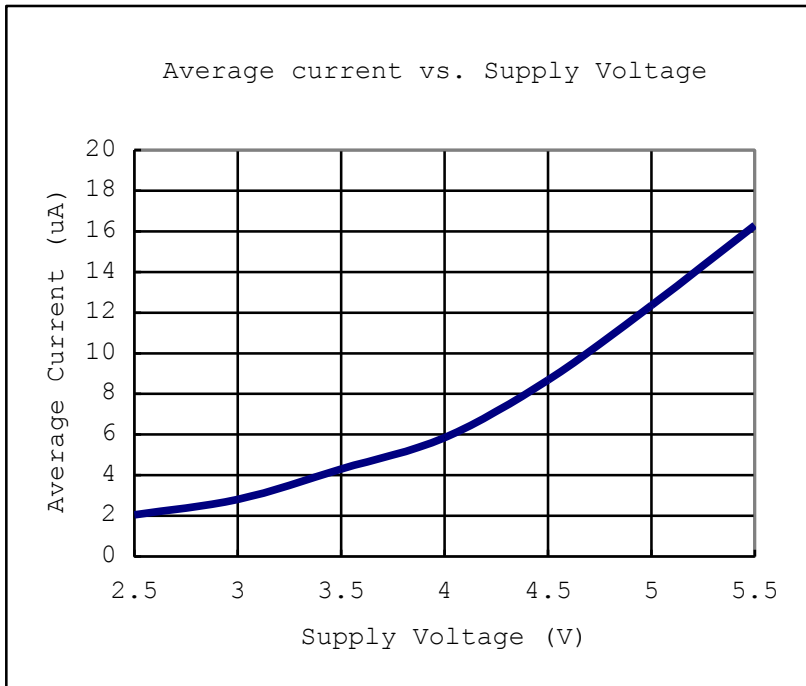

Figure.6 Average Current Versus Supply Voltage (Ta=25C degree)

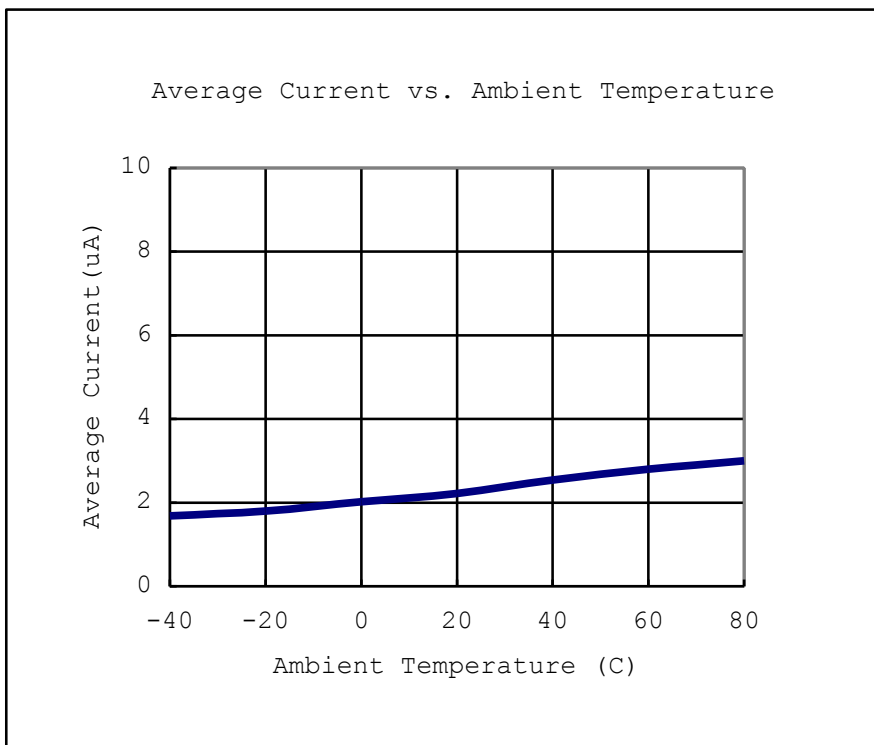
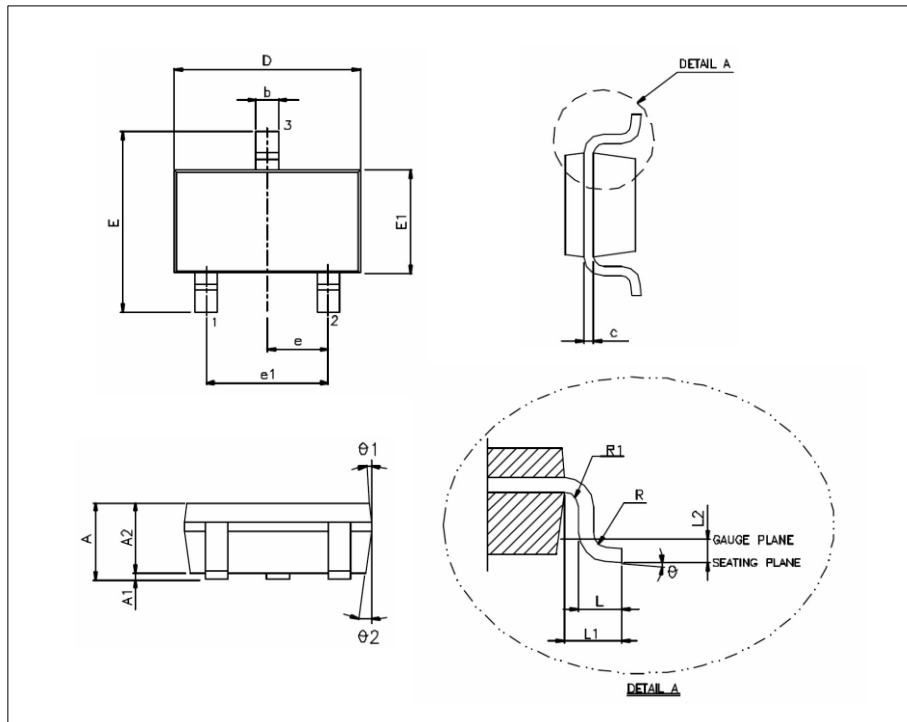

Figure.7 Average Current Versus Ambient Temperature (VDD=2.7V)

This datasheet contains new product information. Feeling Technology reserves the rights to modify the product specification without notice. No liability is assumed as a result of the use of this product. No rights under any patent accompany the sales of the product.

Package Outline

FD2H001BY / SOT23



Unit: mm

Symbols	Dimension In Millimeters		
	Min. (mm)	Nom. (mm)	Max. (mm)
A	-	-	1.45
A1	-	-	0.15
A2	0.90	1.15	1.30
b	0.30	-	0.50
c	0.08	-	0.22
D	2.90 BSC.		
E	2.80 BSC		
E1	1.60 BSC		
e	0.95 BSC		
e1	1.90 BSC		
L	0.30	0.45	0.60
L1	0.60 REF.		
L2	0.25 BSC		
R	0.10	-	-
R1	0.10	-	0.25
θ°	0°	4°	8°
$\theta 1^\circ$	5°	10°	15°

This datasheet contains new product information. Feeling Technology reserves the rights to modify the product specification without notice. No liability is assumed as a result of the use of this product. No rights under any patent accompany the sales of the product.

FD2H001BH / SIP3

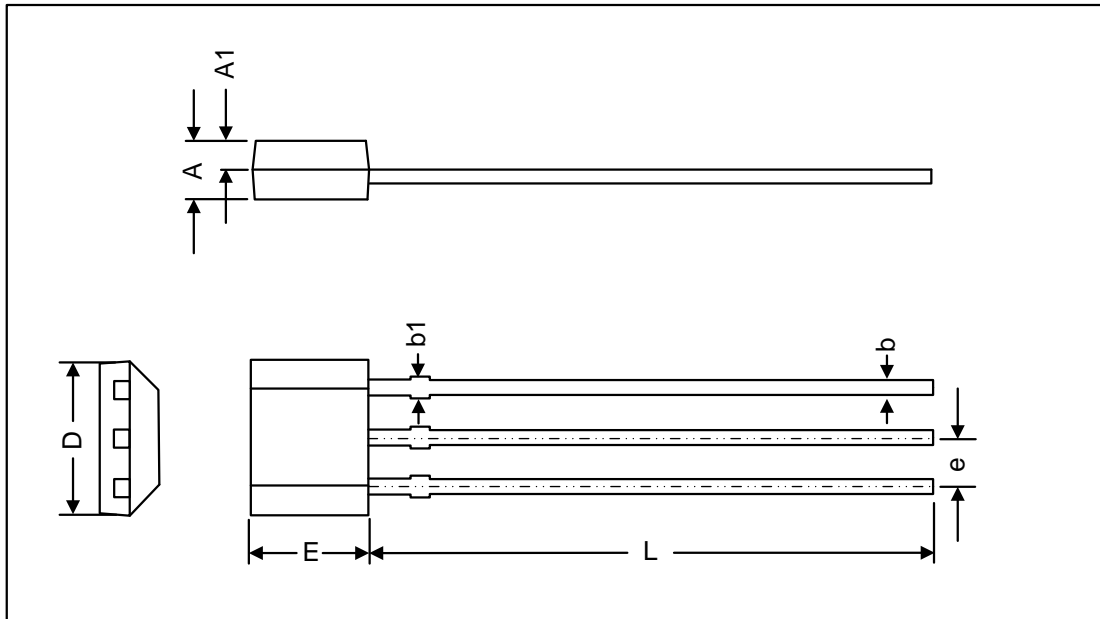

Unit: mm

Symbols	Min. (mm)	Nom. (mm)	Max. (mm)
A	1.245	-	1.753
A1	0.75REF		
b	0.33	-	0.56
b1	0.54 REF		
D	3.85	-	4.2
E	2.87	-	3.124
L	13.5	-	15.6
e	1.27 REF		

Note:

1. Dimension "D" does not include molding flash, protrusions or gate burrs.
2. Dimension "E" does not include interlead flash, protrusions.